

**RACAL INSTRUMENTS™**  
**1260-145**  
**MULTIPLEXER PLUG-IN**

Publication No. 980824-145 Rev. A

**Astronics Test Systems Inc.**

4 Goodyear, Irvine, CA 92618

Tel: (800) 722-2528, (949) 859-8999; Fax: (949) 859-7139

[atsinfo@astronics.com](mailto:atsinfo@astronics.com) [atssales@astronics.com](mailto:atssales@astronics.com)  
[atshelpdesk@astronics.com](mailto:atshelpdesk@astronics.com) <http://www.astronictestsystems.com>

---

---

**THANK YOU FOR PURCHASING THIS  
ASTRONICS TEST SYSTEMS PRODUCT**

---

---

For this product, or any other Astronics Test Systems product that incorporates software drivers, you may access our web site to verify and/or download the latest driver versions. The web address for driver downloads is:

<http://www.astronicstestsystems.com/support/downloads>

If you have any questions about software driver downloads or our privacy policy, please contact us at:

[atsinfo@astronics.com](mailto:atsinfo@astronics.com)

---

---

**WARRANTY STATEMENT**

---

---

All Astronics Test Systems products are designed to exacting standards and manufactured in full compliance to our AS9100 Quality Management System processes.

This warranty does not apply to defects resulting from any modification(s) of any product or part without Astronics Test Systems express written consent, or misuse of any product or part. The warranty also does not apply to fuses, software, non-rechargeable batteries, damage from battery leakage, or problems arising from normal wear, such as mechanical relay life, or failure to follow instructions.

This warranty is in lieu of all other warranties, expressed or implied, including any implied warranty of merchantability or fitness for a particular use. The remedies provided herein are buyer's sole and exclusive remedies.

For the specific terms of your standard warranty, contact Customer Support. Please have the following information available to facilitate service.

1. Product serial number
2. Product model number
3. Your company and contact information

You may contact Customer Support by:

|            |  |       |
|------------|--|-------|
| E-Mail:    | <a href="mailto:atshelpdesk@astronics.com">atshelpdesk@astronics.com</a> |       |
| Telephone: | +1 800 722 3262  | (USA) |
| Fax:       | +1 949 859 7139  | (USA) |

---

---

## RETURN OF PRODUCT

---

---

Authorization is required from Astronics Test Systems before you send us your product or sub-assembly for service or calibration. Call or contact Customer Support at 1-800-722-3262 or 1-949-859-8999 or via fax at 1-949-859-7139. We can also be reached at: [atshelpdesk@astronics.com](mailto:atshelpdesk@astronics.com).

If the original packing material is unavailable, ship the product or sub-assembly in an ESD shielding bag and use appropriate packing materials to surround and protect the product.

---

---

## PROPRIETARY NOTICE

---

---

This document and the technical data herein disclosed, are proprietary to Astronics Test Systems, and shall not, without express written permission of Astronics Test Systems, be used in whole or in part to solicit quotations from a competitive source or used for manufacture by anyone other than Astronics Test Systems. The information herein has been developed at private expense, and may only be used for operation and maintenance reference purposes or for purposes of engineering evaluation and incorporation into technical specifications and other documents which specify procurement of products from Astronics Test Systems.

---

---

## TRADEMARKS AND SERVICE MARKS

---

---

All trademarks and service marks used in this document are the property of their respective owners.

- Racal Instruments, Talon Instruments, Trig-Tek, ActivATE, Adapt-A-Switch, N-GEN, and PAWS are trademarks of Astronics Test Systems in the United States.

---

---

## DISCLAIMER

---

---

Buyer acknowledges and agrees that it is responsible for the operation of the goods purchased and should ensure that they are used properly and in accordance with this document and any other instructions provided by Seller. Astronics Test Systems products are not specifically designed, manufactured or intended to be used as parts, assemblies or components in planning, construction, maintenance or operation of a nuclear facility, or in life support or safety critical applications in which the failure of the Astronics Test Systems product could create a situation where personal injury or death could occur. Should Buyer purchase Astronics Test Systems product for such unintended application, Buyer shall indemnify and hold Astronics Test Systems, its officers, employees, subsidiaries, affiliates and distributors harmless against all claims arising out of a claim for personal injury or death associated with such unintended use.

---

# FOR YOUR SAFETY

---

Before undertaking any troubleshooting, maintenance or exploratory procedure, read carefully the **WARNINGS** and **CAUTION** notices.



**CAUTION**  
RISK OF ELECTRICAL SHOCK  
DO NOT OPEN



This equipment contains voltage hazardous to human life and safety, and is capable of inflicting personal injury.



If this instrument is to be powered from the AC line (mains) through an autotransformer, ensure the common connector is connected to the neutral (earth pole) of the power supply.



Before operating the unit, ensure the conductor (green wire) is connected to the ground (earth) conductor of the power outlet. Do not use a two-conductor extension cord or a three-prong/two-prong adapter. This will defeat the protective feature of the third conductor in the power cord.



Maintenance and calibration procedures sometimes call for operation of the unit with power applied and protective covers removed. Read the procedures and heed warnings to avoid "live" circuit points.

Before operating this instrument:

1. Ensure the proper fuse is in place for the power source to operate.
2. Ensure all other devices connected to or in proximity to this instrument are properly grounded or connected to the protective third-wire earth ground.

If the instrument:

- fails to operate satisfactorily
- shows visible damage
- has been stored under unfavorable conditions
- has sustained stress

Do not operate until performance is checked by qualified personnel.

## EC Declaration of Conformity

We

Astronics Test Systems  
4 Goodyear  
Irvine, CA 92718

declare under sole responsibility that the

**1260-145A thru 1260-145G Multi-Configurable Matrix Switch  
407643-001 thru 407643-007**

conform to the following Product Specifications:

**Safety:** EN 61010-1

**EMC:** EN50081-1  
CISPR 11:1990/EN 55011 (1991): Group 1 Class A  
IEC 801-2:1991/EN 50082-1 (1992): 4 kV CD, 8 kV AD  
IEC 801-3:1984/EN 50082-1 (1992): 3 V/m, 27-500 MHz  
IEC 801-4:1988/EN 50082-1 (1992): 1 kV

### Supplementary Information:

The above specifications are met when the product is installed in an Astronics Test Systems Adapt-a-Switch Carrier with faceplates installed over all unused slots, as applicable. The carrier is installed in a certified mainframe.

The product herewith complies with the requirements of the Low Voltage Directive 73/23/EEC and the EMC Directive 89/336/EEC.

Irvine, CA, August 17, 1999

  
Quality Manager

This page was left intentionally blank.

## Table of Contents

|   |      |
|---|------|
| <b>Chapter 1</b> .....                      | 1-1  |
| MODULE SPECIFICATIONS .....                 | 1-1  |
| Introduction – 1260-145A (9 – 4x4's) .....  | 1-1  |
| Electrical Specifications – 1260-145A ..... | 1-2  |
| Mechanical Specifications – 1260-145A.....  | 1-3  |
| Power Dissipation – 1260-145A .....         | 1-3  |
| Introduction – 1260-145B (3 – 4x12's) ..... | 1-4  |
| Electrical Specifications – 1260-145B ..... | 1-5  |
| Mechanical Specifications – 1260-145B.....  | 1-6  |
| Power Dissipation – 1260-145B .....         | 1-6  |
| Introduction – 1260-145C (2 – 4x16's) ..... | 1-7  |
| Electrical Specifications – 1260-145C ..... | 1-8  |
| Mechanical Specifications – 1260-145C ..... | 1-9  |
| Power Dissipation – 1260-145C .....         | 1-9  |
| Introduction – 1260-145D (1 – 4x36).....    | 1-10 |
| Electrical Specifications – 1260-145D ..... | 1-11 |
| Mechanical Specifications – 1260-145D ..... | 1-12 |
| Power Dissipation – 1260-145D .....         | 1-12 |
| Introduction – 1260-145E (2 – 8x8's) .....  | 1-13 |
| Electrical Specifications – 1260-145E ..... | 1-14 |
| Mechanical Specifications – 1260-145E.....  | 1-15 |
| Power Dissipation – 1260-145E .....         | 1-15 |
| Introduction – 1260-145F (1 – 8x16) .....   | 1-16 |

|   |      |
|---|------|
| Electrical Specifications – 1260-145F ..... | 1-17 |
| Mechanical Specifications – 1260-145F.....  | 1-18 |
| Power Dissipation – 1260-145F .....         | 1-18 |
| Introduction – 1260-145G (1 – 12x12) .....  | 1-19 |
| Electrical Specifications – 1260-145G ..... | 1-20 |
| Mechanical Specifications – 1260-145G ..... | 1-21 |
| Power Dissipation – 1260-145G .....         | 1-21 |
| About MTBF .....                            | 1-22 |
| Ordering Information.....                   | 1-23 |

|                                 |     |
|---------------------------------|-----|
| <b>Chapter 2</b> .....          | 2-1 |
| INSTALLATION INSTRUCTIONS ..... | 2-1 |
| Unpacking and Inspection .....  | 2-1 |
| Installation .....              | 2-2 |
| Module Configuration.....       | 2-2 |
| Front Panel Connectors.....     | 2-2 |
| Mating Connectors.....          | 2-3 |



---

|   |      |
|---|------|
| <b>Chapter 3</b> .....                              | 3-1  |
| MODULE OPERATION.....                               | 3-1  |
| Setting the Module Address .....                    | 3-1  |
| Operating Modes .....                               | 3-2  |
| Operating In Message-Based Mode.....                | 3-4  |
| Channel Descriptors For The 1260-145 .....          | 3-4  |
| Reply To The MOD:LIST? Command .....                | 3-5  |
| Operating The 1260-145 in Register-Based Mode ..... | 3-6  |
| 1260-145 Example Code .....                         | 3-17 |
| <br>  |      |
| <b>Chapter 4</b> .....                              | 4-1  |
| OPTIONAL ASSEMBLIES .....                           | 4-1  |

This page was left intentionally blank.

## List of Figures

|   |      |
|---|------|
| Figure 1-1, The 1260-145 Series .....   | 1-1  |
| Figure 2-1, Front-Panel Connector Pin Numbering .....                             | 2-2  |
| Figure 2-2, 1260-145 Block Diagram .....  | 2-3  |
| Figure 3-1, Message-Based Mode of Operation .....                                 | 3-3  |
| Figure 3-2, Register-Based Mode of Operation.....                                 | 3-3  |
| Figure 3-3, Numbering Nomenclature for all 1260-145 Variants .....                | 3-8  |
| Figure 3-4, Message-Based Channel Descriptor to Physical Switch Orientation ..... | 3-9  |
| Figure 3-5, 1260-145A Connector/Channel Organization.....                         | 3-10 |
| Figure 3-6, 1260-145B Connector/Channel Organization.....                         | 3-11 |
| Figure 3-7, 1260-145C Connector/Channel Organization .....                        | 3-12 |
| Figure 3-8, 1260-145D Connector/Channel Organization .....                        | 3-13 |
| Figure 3-9, 1260-145E Connector/Channel Organization.....                         | 3-14 |
| Figure 3-10, 1260-145F Connector/Channel Organization.....                        | 3-15 |
| Figure 3-11, 1260-145G Connector/Channel Organization .....                       | 3-16 |

## DOCUMENT CHANGE HISTORY

| Revision  | Date     | Description of Change   |
|-----------|----------|---|
| A         | 8/12/08  | Revised per EO 29827<br>Revised format to current standards. Company name revised throughout manual. Manual now revision letter controlled. Added Document Change History Page v.   |
| No change | 03/24/09 | Back of cover sheet. Revised Warranty Statement, Return of Product, Proprietary Notice and Disclaimer to current standards. Removed Reshipment Instructions in (Chap. 2-1) and removed (Chap 5). Information. Now appears in first 2 sheets behind cover sheet. Updated table of contents to reflect changes made. .<br>Added company name to footer at lower corner opposite of Page no's i thru vi. |
|           |          |   |
|           |          |   |
|           |          |   |
|           |          |   |
|           |          |   |
|           |          |   |

## Chapter 1

# MODULE SPECIFICATIONS

### Introduction – 1260-145A (9 – 4x4's)

The 1260-145A is a plug-in matrix switch module developed for the 1260-100 Adapt-a-Switch Carrier. This switch provides nine independent 4x4 matrices with a maximum switching voltage of 125VAC @ 0.3A or 30 VDC @ 1A.

The 1260-145A includes the following features:

- Standard Adapt-a-Switch™ plug-in design, providing for ease of replacement
- Data-Driven embedded descriptor, allowing immediate use with any Option-01T switch controller, regardless of firmware revision level.

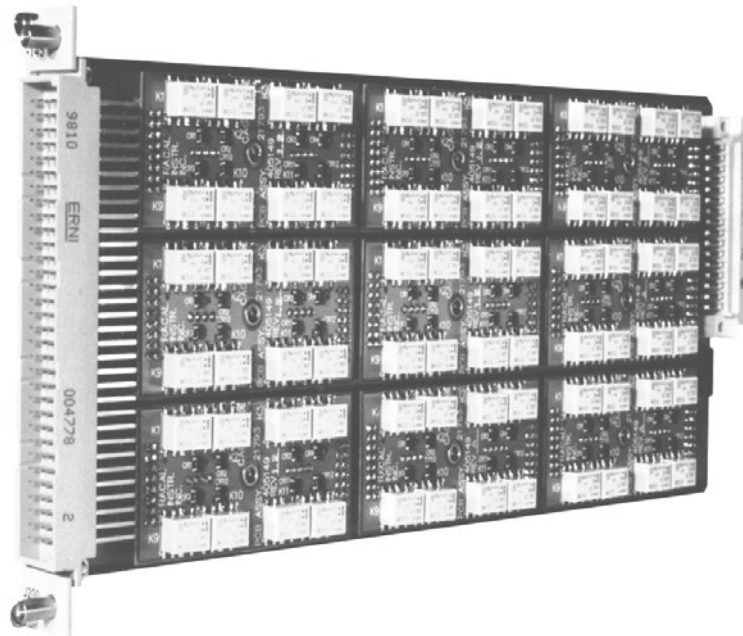

Figure 1-1, The 1260-145 Series

## Electrical Specifications – 1260-145A

|   |   |
|---|---|
| Chan. Input Voltage   | 60 VDC / 125 VAC maximum  |
| Chan. Output Current  | 1 A maximum   |
| Chan. Output Power  | 30 W / 37.5 VA maximum  |
| Path Resistance   | < 1.8 Ohms (HI + LOW path)  |
| Contact Bounce Time   | 3 ms maximum  |
| Contact Thermal EMF   | 4 $\mu$ V maximum   |
| Switch Contact Lifetime                                     | 50 Million Cycles (low-level)<br>100,000 Cycles (maximum rating)  |
| Available I/O Channels                                      | 144 (dual wire)   |
| Capacitance   |   |
| A (HI) to B (LOW)   | 120 pF maximum  |
| Chan. to Chassis  | 415 pF maximum  |
| Bandwidth<br>(Worst Path Performance;<br>Typical Unit)      | 42 MHz (-3 dB) minimum  |
| Insertion Loss<br>(Worst Path Performance;<br>Typical Unit) | 1.0 dB @ 10 MHz maximum<br>0.2 dB @ 1 MHz maximum<br>0.1 dB @ 300 kHz maximum                           |
| Isolation<br>(Worst Path Performance;<br>Typical Unit)      | 15 dB @ 42 MHz minimum<br>43 dB @ 10 MHz minimum<br>62 dB @ 1 MHz minimum<br>76 dB @ 300 kHz minimum    |
| Crosstalk<br>(Worst Path Performance;<br>Typical Unit)      | -9 dB @ 42 MHz maximum<br>-49 dB @ 10 MHz maximum<br>-69 dB @ 1 MHz maximum<br>-81 dB @ 300 kHz maximum |
| Power Requirements  | +5 VDC  |
| quiescent   | 0.1 A maximum   |
| each relay closure  | 0.02 A maximum  |
| Mean Time Between<br>Failures (MTBF)                        | 33,784 Hours (MIL-HDBK-217FN2)<br>50,714 Hours (Telcordia / Bellcore 6)                                 |
| Mean Time to Repair   | < 5 minutes (MTTR)  |

## Mechanical Specifications – 1260-145A

|                   |                                   |
|-------------------|-----------------------------------|
| Shock             | 30g, 11 ms, ½ sine wave           |
| Vibration         | 0.013 in. P-P, 5-55 Hz            |
| Bench Handling    | 4 in., 45°                        |
| Cooling           | See 1260-100 cooling data         |
| Temperature       |                                   |
| Operating         | 0°C to +55°C                      |
| Non-operating     | -40°C to +75°C                    |
| Relative Humidity | 85% + 5% non-condensing at < 30°C |
| Altitude          |                                   |
| Operating         | 10,000 feet                       |
| Non-operating     | 15,000 feet                       |
| Weight            | 9 oz. (0.32 kg.)                  |

## Power Dissipation – 1260-145A

The cooling of the Adapt-a-Switch carrier is dependent upon the chassis into which it is installed. The carrier can nominally dissipate approximately 100W. Even with all channels driven to maximum outputs, up to six 1260-145A plug-ins may be used together in a 1260-100 without exceeding the maximum allowable power dissipation of the carrier.

If the 1260-145A will be used in conjunction with other cards, the dissipation should be computed and summed with the total worst-case dissipation of the remaining modules.

For example, a 1260-145A module would dissipate the following energy:

Quiescent power dissipation = 0.5W maximum

Channel dissipation =  

$$[(\# \text{ channels energized}) * (\text{relay coil dissipation})]$$

Total Power Dissipation = Quiescent + Channel

Assuming all relays on the card are enabled (worse-case situation) the channel path resistances will be in parallel and therefore insignificant as a source of heat. The largest contributor of thermal energy will therefore derive from the relay coils.

Total power dissipation =  $[(144) * (0.100)] + [0.5] = 15W$

This is acceptable power dissipation for an individual plug-in module. If five additional modules are likewise loaded, then the overall carrier dissipation is approximately 90W, which is within the cooling available in most commercial VXIbus chassis. Apart from the thermal issues, however, it is important to remember that a fully enabled 1260-145A card would draw over 3A of current from the +5V supply. If this is multiplied by six for the remaining slots, a load of 18A would burden the +5V supply, exceeding the specifications for the 1260-100 carrier. In reality, the worse-case situation is not likely, since the 1260-145A is a matrix switch where typically only one relay is engaged at a time and the power dissipation falls considerably below that calculated in the example above. For practical purposes, as the calculations can illustrate for normal operation, the 1260-145A contributes a negligible amount of thermal load on a chassis.

## **Introduction – 1260-145B (3 – 4x12's)**

The 1260-145B is a plug-in matrix switch module developed for the 1260-100 Adapt-a-Switch Carrier. This switch provides three independent 4x12 matrices with a maximum switching voltage of 125VAC @ 0.3A or 30 VDC @ 1A.

The 1260-145B includes the following features:

- Standard Adapt-a-Switch™ plug-in design, providing for ease of replacement
- Data-Driven embedded descriptor, allowing immediate use with any Option-01T switch controller, regardless of firmware revision level.



## Electrical Specifications – 1260-145B

|   |  |
|---|--|
| Chan. Input Voltage   | 60 VDC / 125 VAC maximum   |
| Chan. Output Current  | 1 A maximum  |
| Chan. Output Power  | 30 W / 37.5 VA maximum   |
| Path Resistance   | < 1.4 Ohms (HI + LOW path)   |
| Contact Bounce Time   | 3 ms maximum   |
| Contact Thermal EMF   | 4 $\mu$ V maximum  |
| Switch Contact Lifetime                                     | 50 Million Cycles (low-level)<br>100,000 Cycles (maximum rating)   |
| Available I/O Channels                                      | 144 (dual wire)  |
| Capacitance   |  |
| A (HI) to B (LOW)   | 135 pF maximum   |
| Chan. to Chassis  | 500 pF maximum   |
| Bandwidth<br>(Worst Path Performance;<br>Typical Unit)      | 31 MHz (-3 dB) minimum   |
| Insertion Loss<br>(Worst Path Performance;<br>Typical Unit) | 0.5 dB @ 10 MHz maximum<br>0.1 dB @ 1 MHz maximum<br>0.1 dB @ 300 kHz maximum                            |
| Isolation<br>(Worst Path Performance;<br>Typical Unit)      | 22 dB @ 31 MHz minimum<br>52 dB @ 10 MHz minimum<br>68 dB @ 1 MHz minimum<br>75 dB @ 300 kHz minimum     |
| Crosstalk<br>(Worst Path Performance;<br>Typical Unit)      | -16 dB @ 31 MHz maximum<br>-49 dB @ 10 MHz maximum<br>-70 dB @ 1 MHz maximum<br>-72 dB @ 300 kHz maximum |
| Power Requirements  | +5 VDC   |
| quiescent   | 0.1 A maximum  |
| each relay closure  | 0.02 A maximum   |
| Mean Time Between<br>Failures (MTBF)                        | 33,773 Hours (MIL-HDBK-217FN2)<br>50,687 Hours (Telcordia / Bellcore 6)                                  |
| Mean Time to Repair   | < 5 minutes (MTTR)   |

## Mechanical Specifications – 1260-145B

|                   |                                   |
|-------------------|-----------------------------------|
| Shock             | 30g, 11 ms, ½ sine wave           |
| Vibration         | 0.013 in. P-P, 5-55 Hz            |
| Bench Handling    | 4 in., 45°                        |
| Cooling           | See 1260-100 cooling data         |
| Temperature       |                                   |
| Operating         | 0°C to +55°C                      |
| Non-operating     | -40°C to +75°C                    |
| Relative Humidity | 85% + 5% non-condensing at < 30°C |
| Altitude          |                                   |
| Operating         | 10,000 feet                       |
| Non-operating     | 15,000 feet                       |
| Weight            | 9 oz. (0.32 kg.)                  |

## Power Dissipation – 1260-145B

The cooling of the Adapt-a-Switch carrier is dependent upon the chassis into which it is installed. The carrier can nominally dissipate approximately 100W. Even with all channels driven to maximum outputs, up to six 1260-145B plug-ins may be used together in a 1260-100 without exceeding the maximum allowable power dissipation of the carrier.

If the 1260-145B will be used in conjunction with other cards, the dissipation should be computed and summed with the total worst-case dissipation of the remaining modules.

For example, a 1260-145B module would dissipate the following energy:

Quiescent power dissipation = 0.5W maximum

Channel dissipation =  
[(# channels energized) \* (relay coil dissipation)]

Total Power Dissipation = Quiescent + Channel

Assuming all relays on the card are enabled (worse-case situation) the channel path resistances will be in parallel and therefore insignificant as a source of heat. The largest contributor of thermal energy will therefore derive from the relay coils.

Total power dissipation = [(144) \* (0.100)] + [0.5] = 15W

This is acceptable power dissipation for an individual plug-in module. If five additional modules are likewise loaded, then the overall carrier dissipation is approximately 90W, which is within the cooling available in most commercial VXIbus chassis. Apart from the thermal issues, however, it is important to remember that a fully enabled 1260-145B card would draw over 3A of current from the +5V supply. If this is multiplied by six for the remaining slots, a load of 18A would burden the +5V supply, exceeding the specifications for the 1260-100 carrier. In reality, the worse-case situation is not likely, since the 1260-145B is a matrix switch where typically only one relay is engaged at a time and the power dissipation falls considerably below that calculated in the example above. For practical purposes, as the calculations can illustrate for normal operation, the 1260-145B contributes a negligible amount of thermal load on a chassis.

## **Introduction – 1260-145C (2 – 4x16's)**

The 1260-145C is a plug-in matrix switch module developed for the 1260-100 Adapt-a-Switch Carrier. This switch provides two independent 4x16 matrices with a maximum switching voltage of 125VAC @ 0.3A or 30 VDC @ 1A.

The 1260-145C includes the following features:

- Standard Adapt-a-Switch™ plug-in design, providing for ease of replacement
- Data-Driven embedded descriptor, allowing immediate use with any Option-01T switch controller, regardless of firmware revision level.

## Electrical Specifications – 1260-145C

|   |  |
|---|--|
| Chan. Input Voltage   | 60 VDC / 125 VAC maximum   |
| Chan. Output Current  | 1 A maximum  |
| Chan. Output Power  | 30 W / 37.5 VA maximum   |
| Path Resistance   | < 1.6 Ohms (HI + LOW path)   |
| Contact Bounce Time   | 3 ms maximum   |
| Contact Thermal EMF   | 4 $\mu$ V maximum  |
| Switch Contact Lifetime                                     | 50 Million Cycles (low-level)<br>100,000 Cycles (maximum rating)   |
| Available I/O Channels                                      | 128 (dual wire)  |
| Capacitance   |  |
| A (HI) to B (LOW)   | 175 pF maximum   |
| Chan. to Chassis  | 640 pF maximum   |
| Bandwidth<br>(Worst Path Performance;<br>Typical Unit)      | 24 MHz (-3 dB) minimum   |
| Insertion Loss<br>(Worst Path Performance;<br>Typical Unit) | 0.8 dB @ 10 MHz maximum<br>0.1 dB @ 1 MHz maximum<br>0.1 dB @ 300 kHz maximum                            |
| Isolation<br>(Worst Path Performance;<br>Typical Unit)      | 37 dB @ 24 MHz minimum<br>48 dB @ 10 MHz minimum<br>67 dB @ 1 MHz minimum<br>77 dB @ 300 kHz minimum     |
| Crosstalk<br>(Worst Path Performance;<br>Typical Unit)      | -19 dB @ 24 MHz maximum<br>-46 dB @ 10 MHz maximum<br>-59 dB @ 1 MHz maximum<br>-63 dB @ 300 kHz maximum |
| Power Requirements  | +5 VDC   |
| quiescent   | 0.1 A maximum  |
| each relay closure  | 0.02 A maximum   |
| Mean Time Between<br>Failures (MTBF)                        | 37,908 Hours (MIL-HDBK-217FN2)<br>56,705 Hours (Telcordia / Bellcore 6)                                  |
| Mean Time to Repair   | < 5 minutes (MTTR)   |

## Mechanical Specifications – 1260-145C

|                   |                                   |
|-------------------|-----------------------------------|
| Shock             | 30g, 11 ms, ½ sine wave           |
| Vibration         | 0.013 in. P-P, 5-55 Hz            |
| Bench Handling    | 4 in., 45°                        |
| Cooling           | See 1260-100 cooling data         |
| Temperature       |                                   |
| Operating         | 0°C to +55°C                      |
| Non-operating     | -40°C to +75°C                    |
| Relative Humidity | 85% + 5% non-condensing at < 30°C |
| Altitude          |                                   |
| Operating         | 10,000 feet                       |
| Non-operating     | 15,000 feet                       |
| Weight            | 9 oz. (0.32 kg.)                  |

## Power Dissipation – 1260-145C

The cooling of the Adapt-a-Switch carrier is dependent upon the chassis into which it is installed. The carrier can nominally dissipate approximately 100W. Even with all channels driven to maximum outputs, up to six 1260-145C plug-ins may be used together in a 1260-100 without exceeding the maximum allowable power dissipation of the carrier.

If the 1260-145C will be used in conjunction with other cards, the dissipation should be computed and summed with the total worst-case dissipation of the remaining modules.

For example, a 1260-145C module would dissipate the following energy:

Quiescent power dissipation = 0.5W maximum

Channel dissipation =  

$$[(\# \text{ channels energized}) * (\text{relay coil dissipation})]$$

Total Power Dissipation = Quiescent + Channel

Assuming all relays on the card are enabled (worse-case situation) the channel path resistances will be in parallel and therefore insignificant as a source of heat. The largest contributor of thermal energy will therefore derive from the relay coils.

Total power dissipation =  $[(128) * (0.100)] + [0.5] = 13.3W$

This is acceptable power dissipation for an individual plug-in module. If five additional modules are likewise loaded, then the overall carrier dissipation is approximately 80W, which is within the cooling available in most commercial VXIbus chassis. Apart from the thermal issues, however, it is important to remember that a fully enabled 1260-145C card would draw over 2.7A of current from the +5V supply. If this is multiplied by six for the remaining slots, a load of 16A would burden the +5V supply, exceeding the specifications for the 1260-100 carrier. In reality, the worse-case situation is not likely, since the 1260-145C is a matrix switch where typically only one relay is engaged at a time and the power dissipation falls considerably below that calculated in the example above. For practical purposes, as the calculations can illustrate for normal operation, the 1260-145C contributes a negligible amount of thermal load on a chassis.

## **Introduction – 1260-145D (1 – 4x36)**

The 1260-145D is a plug-in matrix switch module developed for the 1260-100 Adapt-a-Switch Carrier. This switch provides a 4x36 matrix with a maximum switching voltage of 125VAC @ 0.3A or 30 VDC @ 1A.

The 1260-145D includes the following features:

- Standard Adapt-a-Switch™ plug-in design, providing for ease of replacement
- Data-Driven embedded descriptor, allowing immediate use with any Option-01T switch controller, regardless of firmware revision level.

## Electrical Specifications – 1260-145D

|   |  |
|---|--|
| Chan. Input Voltage   | 60 VDC / 125 VAC maximum   |
| Chan. Output Current  | 1 A maximum  |
| Chan. Output Power  | 30 W / 37.5 VA maximum   |
| Path Resistance   | < 1.6 Ohms (HI + LOW path)   |
| Contact Bounce Time   | 3 ms maximum   |
| Contact Thermal EMF   | 4 $\mu$ V maximum  |
| Switch Contact Lifetime                                     | 50 Million Cycles (low-level)<br>100,000 Cycles (maximum rating)   |
| Available I/O Channels                                      | 144 (dual wire)  |
| Capacitance   |  |
| A (HI) to B (LOW)   | 310 pF maximum   |
| Chan. to Chassis  | 1485 pF maximum  |
| Bandwidth<br>(Worst Path Performance;<br>Typical Unit)      | 13 MHz (-3 dB) minimum   |
| Insertion Loss<br>(Worst Path Performance;<br>Typical Unit) | 2.0 dB @ 10 MHz maximum<br>0.1 dB @ 1 MHz maximum<br>0.1 dB @ 300 kHz maximum                            |
| Isolation<br>(Worst Path Performance;<br>Typical Unit)      | 37 dB @ 13 MHz minimum<br>44 dB @ 10 MHz minimum<br>67 dB @ 1 MHz minimum<br>75 dB @ 300 kHz minimum     |
| Crosstalk<br>(Worst Path Performance;<br>Typical Unit)      | -38 dB @ 13 MHz maximum<br>-42 dB @ 10 MHz maximum<br>-68 dB @ 1 MHz maximum<br>-75 dB @ 300 kHz maximum |
| Power Requirements  | +5 VDC   |
| quiescent   | 0.1 A maximum  |
| each relay closure  | 0.02 A maximum   |
| Mean Time Between<br>Failures (MTBF)                        | 33,768 Hours (MIL-HDBK-217FN2)<br>50,673 Hours (Telcordia / Bellcore 6)                                  |
| Mean Time to Repair   | < 5 minutes (MTTR)   |

## Mechanical Specifications – 1260-145D

|                   |                                   |
|-------------------|-----------------------------------|
| Shock             | 30g, 11 ms, ½ sine wave           |
| Vibration         | 0.013 in. P-P, 5-55 Hz            |
| Bench Handling    | 4 in., 45°                        |
| Cooling           | See 1260-100 cooling data         |
| Temperature       |                                   |
| Operating         | 0°C to +55°C                      |
| Non-operating     | -40°C to +75°C                    |
| Relative Humidity | 85% + 5% non-condensing at < 30°C |
| Altitude          |                                   |
| Operating         | 10,000 feet                       |
| Non-operating     | 15,000 feet                       |
| Weight            | 9 oz. (0.32 kg.)                  |

## Power Dissipation – 1260-145D

The cooling of the Adapt-a-Switch carrier is dependent upon the chassis into which it is installed. The carrier can nominally dissipate approximately 100W. Even with all channels driven to maximum outputs, up to six 1260-145D plug-ins may be used together in a 1260-100 without exceeding the maximum allowable power dissipation of the carrier.

If the 1260-145D will be used in conjunction with other cards, the dissipation should be computed and summed with the total worst-case dissipation of the remaining modules.

For example, a 1260-145D module would dissipate the following energy:

Quiescent power dissipation = 0.5W maximum

Channel dissipation =  
 [(# channels energized) \* (relay coil dissipation)]

Total Power Dissipation = Quiescent + Channel

Assuming all relays on the card are enabled (worse-case situation) the channel path resistances will be in parallel and therefore insignificant as a source of heat. The largest contributor of thermal energy will therefore derive from the relay coils.

Total power dissipation = [(144) \* (0.100)] + [0.5] = 15W



This is acceptable power dissipation for an individual plug-in module. If five additional modules are likewise loaded, then the overall carrier dissipation is approximately 90W, which is within the cooling available in most commercial VXIbus chassis. Apart from the thermal issues, however, it is important to remember that a fully enabled 1260-145D card would draw over 3A of current from the +5V supply. If this is multiplied by six for the remaining slots, a load of 18A would burden the +5V supply, exceeding the specifications for the 1260-100 carrier. In reality, the worse-case situation is not likely, since the 1260-145D is a matrix switch where typically only one relay is engaged at a time and the power dissipation falls considerably below that calculated in the example above. For practical purposes, as the calculations can illustrate for normal operation, the 1260-145D contributes a negligible amount of thermal load on a chassis.

## **Introduction – 1260-145E (2 – 8x8's)**

The 1260-145E is a plug-in matrix switch module developed for the 1260-100 Adapt-a-Switch Carrier. This switch provides two independent 8x8 matrices with a maximum switching voltage of 125VAC @ 0.3A or 30 VDC @ 1A.

The 1260-145E includes the following features:

- Standard Adapt-a-Switch™ plug-in design, providing for ease of replacement
- Data-Driven embedded descriptor, allowing immediate use with any Option-01T switch controller, regardless of firmware revision level.

## Electrical Specifications – 1260-145E

|   |  |
|---|--|
| Chan. Input Voltage   | 60 VDC / 125 VAC maximum   |
| Chan. Output Current  | 1 A maximum  |
| Chan. Output Power  | 30 W / 37.5 VA maximum   |
| Path Resistance   | < 2 Ohms (HI + LOW path)   |
| Contact Bounce Time   | 3 ms maximum   |
| Contact Thermal EMF   | 4 $\mu$ V maximum  |
| Switch Contact Lifetime                                     | 50 Million Cycles (low-level)<br>100,000 Cycles (maximum rating)   |
| Available I/O Channels                                      | 128 (dual wire)  |
| Capacitance   |  |
| A (HI) to B (LOW)   | 175 pF maximum   |
| Chan. to Chassis  | 640 pF maximum   |
| Bandwidth<br>(Worst Path Performance;<br>Typical Unit)      | 27 MHz (-3 dB) minimum   |
| Insertion Loss<br>(Worst Path Performance;<br>Typical Unit) | 0.7 dB @ 10 MHz maximum<br>0.2 dB @ 1 MHz maximum<br>0.1 dB @ 300 kHz maximum                            |
| Isolation<br>(Worst Path Performance;<br>Typical Unit)      | 29 dB @ 27 MHz minimum<br>43 dB @ 10 MHz minimum<br>61 dB @ 1 MHz minimum<br>74 dB @ 300 kHz minimum     |
| Crosstalk<br>(Worst Path Performance;<br>Typical Unit)      | -15 dB @ 27 MHz maximum<br>-46 dB @ 10 MHz maximum<br>-64 dB @ 1 MHz maximum<br>-72 dB @ 300 kHz maximum |
| Power Requirements  | +5 VDC   |
| quiescent   | 0.1 A maximum  |
| each relay closure  | 0.02 A maximum   |
| Mean Time Between<br>Failures (MTBF)                        | 37,904 Hours (MIL-HDBK-217FN2)<br>56,694 Hours (Telcordia / Bellcore 6)                                  |
| Mean Time to Repair   | < 5 minutes (MTTR)   |

## Mechanical Specifications – 1260-145E

|                   |                                   |
|-------------------|-----------------------------------|
| Shock             | 30g, 11 ms, ½ sine wave           |
| Vibration         | 0.013 in. P-P, 5-55 Hz            |
| Bench Handling    | 4 in., 45°                        |
| Cooling           | See 1260-100 cooling data         |
| Temperature       |                                   |
| Operating         | 0°C to +55°C                      |
| Non-operating     | -40°C to +75°C                    |
| Relative Humidity | 85% + 5% non-condensing at < 30°C |
| Altitude          |                                   |
| Operating         | 10,000 feet                       |
| Non-operating     | 15,000 feet                       |
| Weight            | 9 oz. (0.32 kg.)                  |

## Power Dissipation – 1260-145E

The cooling of the Adapt-a-Switch carrier is dependent upon the chassis into which it is installed. The carrier can nominally dissipate approximately 100W. Even with all channels driven to maximum outputs, up to six 1260-145E plug-ins may be used together in a 1260-100 without exceeding the maximum allowable power dissipation of the carrier.

If the 1260-145E will be used in conjunction with other cards, the dissipation should be computed and summed with the total worst-case dissipation of the remaining modules.

For example, a 1260-145E module would dissipate the following energy:

Quiescent power dissipation = 0.5W maximum

Channel dissipation =  

$$[(\# \text{ channels energized}) * (\text{relay coil dissipation})]$$

Total Power Dissipation = Quiescent + Channel

Assuming all relays on the card are enabled (worse-case situation) the channel path resistances will be in parallel and therefore insignificant as a source of heat. The largest contributor of thermal energy will therefore derive from the relay coils.

Total power dissipation =  $[(128) * (0.100)] + [0.5] = 13.3W$

This is acceptable power dissipation for an individual plug-in module. If five additional modules are likewise loaded, then the overall carrier dissipation is approximately 80W, which is within the cooling available in most commercial VXIbus chassis. Apart from the thermal issues, however, it is important to remember that a fully enabled 1260-145E card would draw over 2.7A of current from the +5V supply. If this is multiplied by six for the remaining slots, a load of 16A would burden the +5V supply, exceeding the specifications for the 1260-100 carrier. In reality, the worse-case situation is not likely, since the 1260-145E is a matrix switch where typically only one relay is engaged at a time and the power dissipation falls considerably below that calculated in the example above. For practical purposes, as the calculations can illustrate for normal operation, the 1260-145E contributes a negligible amount of thermal load on a chassis.

## **Introduction – 1260-145F (1 – 8x16)**

The 1260-145F is a plug-in matrix switch module developed for the 1260-100 Adapt-a-Switch Carrier. This switch provides a 8x16 matrix with a maximum switching voltage of 125VAC @ 0.3A or 30 VDC @ 1A.

The 1260-145F includes the following features:

- Standard Adapt-a-Switch™ plug-in design, providing for ease of replacement
- Data-Driven embedded descriptor, allowing immediate use with any Option-01T switch controller, regardless of firmware revision level.

## Electrical Specifications – 1260-145F

|   |  |
|---|--|
| Chan. Input Voltage   | 60 VDC / 125 VAC maximum   |
| Chan. Output Current  | 1 A maximum  |
| Chan. Output Power  | 30 W / 37.5 VA maximum   |
| Path Resistance   | < 1.8 Ohms (HI + LOW path)   |
| Contact Bounce Time   | 3 ms maximum   |
| Contact Thermal EMF   | 4 $\mu$ V maximum  |
| Switch Contact Lifetime                                     | 50 Million Cycles (low-level)<br>100,000 Cycles (maximum rating)   |
| Available I/O Channels                                      | 128 (dual wire)  |
| Capacitance   |  |
| A (HI) to B (LOW)   | 225 pF maximum   |
| Chan. to Chassis  | 840 pF maximum   |
| Bandwidth<br>(Worst Path Performance;<br>Typical Unit)      | 20 MHz (-3 dB) minimum   |
| Insertion Loss<br>(Worst Path Performance;<br>Typical Unit) | 1.2 dB @ 10 MHz maximum<br>0.2 dB @ 1 MHz maximum<br>0.1 dB @ 300 kHz maximum                            |
| Isolation<br>(Worst Path Performance;<br>Typical Unit)      | 30 dB @ 20 MHz minimum<br>53 dB @ 10 MHz minimum<br>66 dB @ 1 MHz minimum<br>79 dB @ 300 kHz minimum     |
| Crosstalk<br>(Worst Path Performance;<br>Typical Unit)      | -30 dB @ 20 MHz maximum<br>-44 dB @ 10 MHz maximum<br>-62 dB @ 1 MHz maximum<br>-77 dB @ 300 kHz maximum |
| Power Requirements  | +5 VDC   |
| quiescent   | 0.1 A maximum  |
| each relay closure  | 0.02 A maximum   |
| Mean Time Between<br>Failures (MTBF)                        | 37,899 Hours (MIL-HDBK-217FN2)<br>56,682 Hours (Telcordia / Bellcore 6)                                  |
| Mean Time to Repair   | < 5 minutes (MTTR)   |

## Mechanical Specifications – 1260-145F

|                   |                                   |
|-------------------|-----------------------------------|
| Shock             | 30g, 11 ms, ½ sine wave           |
| Vibration         | 0.013 in. P-P, 5-55 Hz            |
| Bench Handling    | 4 in., 45°                        |
| Cooling           | See 1260-100 cooling data         |
| Temperature       |                                   |
| Operating         | 0°C to +55°C                      |
| Non-operating     | -40°C to +75°C                    |
| Relative Humidity | 85% + 5% non-condensing at < 30°C |
| Altitude          |                                   |
| Operating         | 10,000 feet                       |
| Non-operating     | 15,000 feet                       |
| Weight            | 9 oz. (0.32 kg.)                  |

## Power Dissipation – 1260-145F

The cooling of the Adapt-a-Switch carrier is dependent upon the chassis into which it is installed. The carrier can nominally dissipate approximately 100W. Even with all channels driven to maximum outputs, up to six 1260-145F plug-ins may be used together in a 1260-100 without exceeding the maximum allowable power dissipation of the carrier.

If the 1260-145F will be used in conjunction with other cards, the dissipation should be computed and summed with the total worst-case dissipation of the remaining modules.

For example, a 1260-145F module would dissipate the following energy:

Quiescent power dissipation = 0.5W maximum

Channel dissipation =  
 [(# channels energized) \* (relay coil dissipation)]

Total Power Dissipation = Quiescent + Channel

Assuming all relays on the card are enabled (worse-case situation) the channel path resistances will be in parallel and therefore insignificant as a source of heat. The largest contributor of thermal energy will therefore derive from the relay coils.

Total power dissipation = [(128) \* (0.100)] + [0.5] = 13.3W

This is acceptable power dissipation for an individual plug-in module. If five additional modules are likewise loaded, then the overall carrier dissipation is approximately 80W, which is within the cooling available in most commercial VXIbus chassis. Apart from the thermal issues, however, it is important to remember that a fully enabled 1260-145F card would draw over 2.7A of current from the +5V supply. If this is multiplied by six for the remaining slots, a load of 16A would burden the +5V supply, exceeding the specifications for the 1260-100 carrier. In reality, the worse-case situation is not likely, since the 1260-145F is a matrix switch where typically only one relay is engaged at a time and the power dissipation falls considerably below that calculated in the example above. For practical purposes, as the calculations can illustrate for normal operation, the 1260-145F contributes a negligible amount of thermal load on a chassis.

## **Introduction – 1260-145G (1 – 12x12)**

The 1260-145G is a plug-in matrix switch module developed for the 1260-100 Adapt-a-Switch Carrier. This switch provides a 12x12 matrix with a maximum switching voltage of 125VAC @ 0.3A or 30 VDC @ 1A.

The 1260-145G includes the following features:

- Standard Adapt-a-Switch™ plug-in design, providing for ease of replacement
- Data-Driven embedded descriptor, allowing immediate use with any Option-01T switch controller, regardless of firmware revision level.

## Electrical Specifications – 1260-145G

|   |  |
|---|--|
| Chan. Input Voltage   | 60 VDC / 125 VAC maximum   |
| Chan. Output Current  | 1 A maximum  |
| Chan. Output Power  | 30 W / 37.5 VA maximum   |
| Path Resistance   | < 1.5 Ohms (HI + LOW path)   |
| Contact Bounce Time   | 3 ms maximum   |
| Contact Thermal EMF   | 4 $\mu$ V maximum  |
| Switch Contact Lifetime                                     | 50 Million Cycles (low-level)<br>100,000 Cycles (maximum rating)   |
| Available I/O Channels                                      | 144 (dual wire)  |
| Capacitance   |  |
| A (HI) to B (LOW)   | 175 pF maximum   |
| Chan. to Chassis  | 625 pF maximum   |
| Bandwidth<br>(Worst Path Performance;<br>Typical Unit)      | 27 MHz (-3 dB) minimum   |
| Insertion Loss<br>(Worst Path Performance;<br>Typical Unit) | 0.7 dB @ 10 MHz maximum<br>0.1 dB @ 1 MHz maximum<br>0.1 dB @ 300 kHz maximum                            |
| Isolation<br>(Worst Path Performance;<br>Typical Unit)      | 24 dB @ 27 MHz minimum<br>52 dB @ 10 MHz minimum<br>67 dB @ 1 MHz minimum<br>74 dB @ 300 kHz minimum     |
| Crosstalk<br>(Worst Path Performance;<br>Typical Unit)      | -28 dB @ 27 MHz maximum<br>-44 dB @ 10 MHz maximum<br>-65 dB @ 1 MHz maximum<br>-70 dB @ 300 kHz maximum |
| Power Requirements  | +5 VDC   |
| quiescent   | 0.1 A maximum  |
| each relay closure  | 0.02 A maximum   |
| Mean Time Between<br>Failures (MTBF)                        | 33,763 Hours (MIL-HDBK-217FN2)<br>50,660 Hours (Telcordia / Bellcore 6)                                  |
| Mean Time to Repair   | < 5 minutes (MTTR)   |



## Mechanical Specifications – 1260-145G

|                   |                                   |
|-------------------|-----------------------------------|
| Shock             | 30g, 11 ms, ½ sine wave           |
| Vibration         | 0.013 in. P-P, 5-55 Hz            |
| Bench Handling    | 4 in., 45°                        |
| Cooling           | See 1260-100 cooling data         |
| Temperature       |                                   |
| Operating         | 0°C to +55°C                      |
| Non-operating     | -40°C to +75°C                    |
| Relative Humidity | 85% + 5% non-condensing at < 30°C |
| Altitude          |                                   |
| Operating         | 10,000 feet                       |
| Non-operating     | 15,000 feet                       |
| Weight            | 9 oz. (0.32 kg.)                  |

## Power Dissipation – 1260-145G

The cooling of the Adapt-a-Switch carrier is dependent upon the chassis into which it is installed. The carrier can nominally dissipate approximately 100W. Even with all channels driven to maximum outputs, up to six 1260-145G plug-ins may be used together in a 1260-100 without exceeding the maximum allowable power dissipation of the carrier.

If the 1260-145G will be used in conjunction with other cards, the dissipation should be computed and summed with the total worst-case dissipation of the remaining modules.

For example, a 1260-145G module would dissipate the following energy:

Quiescent power dissipation = 0.5W maximum

Channel dissipation =  

$$[(\# \text{ channels energized}) * (\text{relay coil dissipation})]$$

Total Power Dissipation = Quiescent + Channel

Assuming all relays on the card are enabled (worse-case situation) the channel path resistances will be in parallel and therefore insignificant as a source of heat. The largest contributor of thermal energy will therefore derive from the relay coils.

Total power dissipation =  $[(144) * (0.100)] + [0.5] = 15W$

This is acceptable power dissipation for an individual plug-in module. If five additional modules are likewise loaded, then the overall carrier dissipation is approximately 90W, which is within the cooling available in most commercial VXIbus chassis. Apart from the thermal issues, however, it is important to remember that a fully enabled 1260-145G card would draw over 3A of current from the +5V supply. If this is multiplied by six for the remaining slots, a load of 18A would burden the +5V supply, exceeding the specifications for the 1260-100 carrier. In reality, the worse-case situation is not likely, since the 1260-145G is a matrix switch where typically only one relay is engaged at a time and the power dissipation falls considerably below that calculated in the example above. For practical purposes, as the calculations can illustrate for normal operation, the 1260-145G contributes a negligible amount of thermal load on a chassis.

## About MTBF

The 1260-145 MTBF is calculated in accordance with MIL-HDBK-217FN2 and Telcordia (Bellcore) 6 procedures. Refer to the specifications for each card for calculated MTBF values.

## Ordering Information

Listed below are part numbers for both the 1260-145 switch module and available mating connector accessories. Each 1260-145 uses a single mating connector.

| ITEM                     | DESCRIPTION   | PART #     |
|--------------------------|---|------------|
| 1260-145A Switch Module  | 1260-145A, 9 4x4 Matrix Switch<br>Consists of:<br>P/N 405139-001 PCB Assy<br>P/N 980824-145 Manual  | 407643-001 |
| 1260-145B Switch Module  | 1260-145B, 3 4x12 Matrix Switch<br>Consists of:<br>P/N 405139-002 PCB Assy<br>P/N 980824-145 Manual | 407643-002 |
| 1260-145C Switch Module  | 1260-145C, 2 4x16 Matrix Switch<br>Consists of:<br>P/N 405139-003 PCB Assy<br>P/N 980824-145 Manual | 407643-003 |
| 1260-145D Switch Module  | 1260-145D, 1 4x36 Matrix Switch<br>Consists of:<br>P/N 405139-004 PCB Assy<br>P/N 980824-145 Manual | 407643-004 |
| 1260-145E Switch Module  | 1260-145E, 2 8x8 Matrix Switch<br>Consists of:<br>P/N 405139-005 PCB Assy<br>P/N 980824-145 Manual  | 407643-005 |
| 1260-145F Switch Module  | 1260-145F, 1 8x16 Matrix Switch<br>Consists of:<br>P/N 405139-006 PCB Assy<br>P/N 980824-145 Manual | 407643-006 |
| 1260-145G Switch Module  | 1260-145G, 3 4x12 Matrix Switch<br>Consists of:<br>P/N 405139-007 PCB Assy<br>P/N 980824-145 Manual | 407643-007 |
| 160-pin Mating Connector | 160 Pin Conn. Kit with pins   | 407664     |
| Cable Assy. 6ft, Sleeved | 160 Pin Cable Assy, 6 Ft, 24 AWG  | 407408-001 |
| Connector Bracket        | Bracket, Strain Relief  | 456673     |
| Additional Manual        |   | 980824-145 |

This page was left intentionally blank.

## Chapter 2

# INSTALLATION INSTRUCTIONS

---

### Unpacking and Inspection

1. Remove the 1260-145 module and inspect it for damage. If any damage is apparent, inform the carrier immediately. Retain shipping carton and packing material for the carrier's inspection.
2. Verify that the pieces in the package you received contain the correct 1260-145 module option and the 1260-145 Users Manual. Notify Customer Support if the module appears damaged in any way. Do not attempt to install a damaged module into a VXI chassis.
3. The 1260-145 module is shipped in an anti-static bag to prevent electrostatic damage to the module. Do not remove the module from the anti-static bag unless it is in a static-controlled area.

## Installation

Installation of the 1260-145 Switching Module into a 1260-100 Carrier assembly is described in the Installation section of the 1260-100 Adapt-a-Switch Carrier Manual.

## Module Configuration

The 1260-145 module is available in seven different configurations providing a wide variety of matrix sizes. Refer to Chapter 1 for more information about specific configurations.

## Front Panel Connectors

The 1260-145 has one 160-pin front-panel connector, labeled J200. It is a 160-pin, DIN “E” style, with 0.040” rectangular posts as pins. See **Figure 2-1** for pin numbering. Refer to Chapter 3 for channel to pin mapping. For a block diagram of the 1260-145 see **Figure 2-2**.

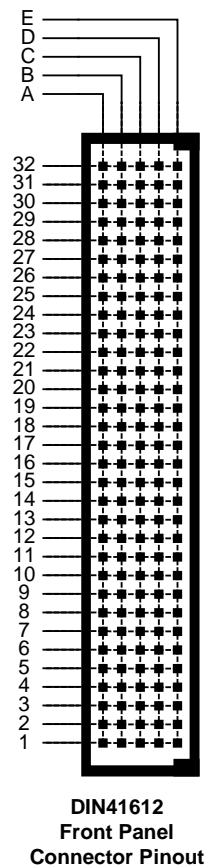

**Figure 2-1, Front-Panel Connector Pin Numbering**

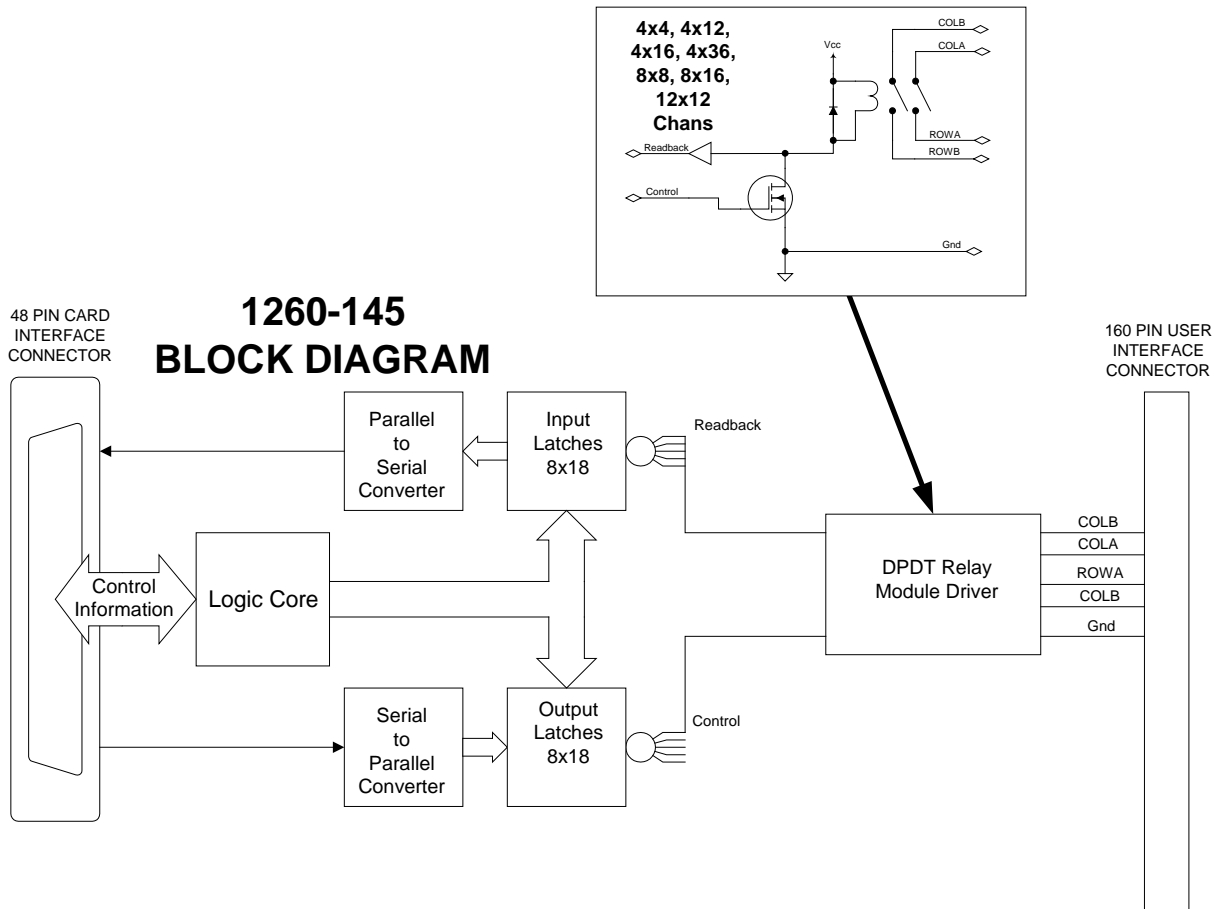

Figure 2-2, 1260-145 Block Diagram

## Mating Connectors

Mating connector accessories are available:

160-Pin Connector Kit with backshell and pins,  
P/N 407664

160-Pin Cable Assembly, 6 Ft., 24 AWG,  
P/N 407408-001

The 160-Pin Connector Kit consists of a connector housing, and 170 crimp pins. After wire attachment, the pin is inserted into the housing and will snap into place, providing positive retention.

The suggested crimp tool for the crimp pins is P/N 990897. The corresponding pin insertion tool is P/N 990898 and the removal tool is P/N 990899.

The 160-Pin Cable Assembly uses 24 AWG cable with crimp pins to mate with the 1260-145. The other cable end is un-terminated. Refer to **Chapter 3** for channel-to-pin mapping information.

This page was left intentionally blank.



## Chapter 3

# MODULE OPERATION

### Setting the Module Address

The Option-01T switch controller identifies each Adapt-a-Switch plug-in or conventional 1260-Series module by a *module address* that is unique to that module. The module address is a number from 1 through 12, inclusive.

The module address assigned to the 1260-145 depends on the carrier slot into which the 1260-145 is inserted, and on the position of the logical address DIP switch on the carrier side panel. The switch has two settings:

- ! 1-6 (closed): When the switch is set to this position, the module addresses of the plug-ins in the 1260-100 Carrier are from 1 through 6. The module with address 1 is in the left slot of the top row. The plug-ins are addressed in the following pattern:

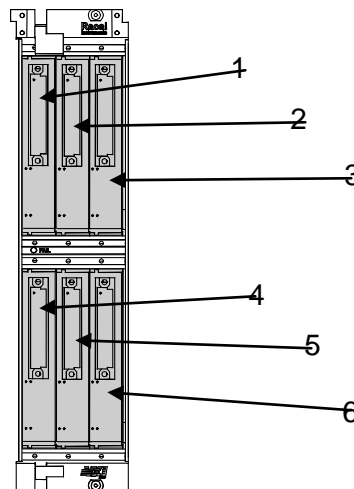

Front View – Module Addresses for 1 through 6

- 7 - 12 (open): When the switch is set to this position, the module addresses of the plug-ins in the 1260-100 Carrier are from 7 through 12, in the following pattern:

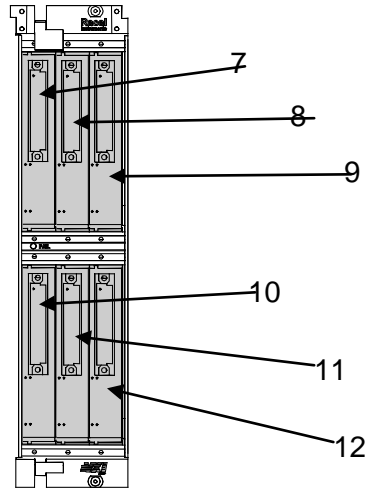

**Front View – Module Addresses for 7 through 12**

When setting module addresses for Adapt-a-Switch Carriers and conventional 1260-Series modules, be sure that no address is used by more than one plug-in or 1260-Series module.

For instructions on setting module addresses for a conventional 1260-Series module, see the label on the side panel of the module.

## Operating Modes

The 1260-145 may be operated either in *message-based* mode or in *register-based* mode.

In the *message-based* mode, the 1260-01T switch controller interprets commands sent by the slot 0 controller, and determines the appropriate data to send to the control registers of the 1260-145 module.

If the A24 VXI base address for the 1260-100 Adapt-A-Switch carrier is assumed to be at 0x804000A for example purposes and the 1260-145 occupies the module 0 slot, **Figure 3-1** below provides a conceptual view of the message-based mode of operation for a read operation on port 1.

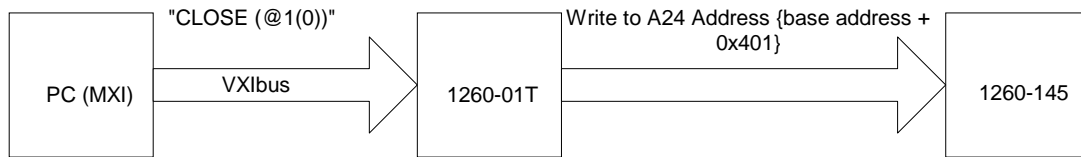

**Figure 3-1, Message-Based Mode of Operation**

In the *register-based* mode, the user writes directly to the port registers on the 1260-145 module. The 1260-01T command module does not monitor these operations, and does not keep track of the port states on the 1260-145 module in this mode.

A conceptual view of the register-based mode is shown in **Figure 3-2** below.

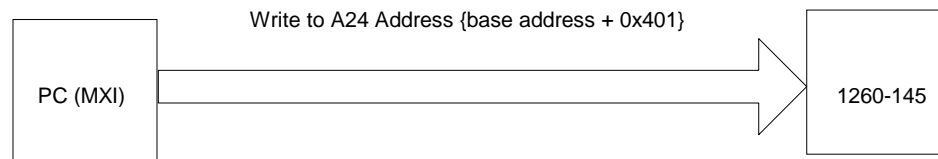

**Figure 3-2, Register-Based Mode of Operation**

Since the 1260-01T switch controller does not keep track of port and control register states during the register-based mode, it is advisable to use **either** the message-based or the register-based mode consistently, and use the chosen mode exclusively throughout the application program.

In general, the message-based mode of operation is easier to use with utility software such as the National Instruments VXI Interactive Control (VIC) program. The message-based mode allows the user to send ASCII text commands to the 1260-01T and to read replies from the 1260-01T. In addition, some features, such as scan lists, are available only in the message-based mode.

The register-based mode provides faster and more direct control of the 1260-145. In this mode, direct port and control register operations are processed in less than 9 microseconds, not counting software overhead inherent in I/O libraries such as VISA.

For further information about message-based vs. register-based

comparisons, consult the 1260-01T User's Manual for further details.

## Operating In Message-Based Mode

### Channel Descriptors For The 1260-145

The standard 1260-01T commands are used to operate the 1260-145 module. These commands are described in the 1260-01T User's Manual.

Each 1260-01T port command uses a *channel descriptor* to select the channel(s) of interest. The syntax for a channel descriptor is the same for all 1260 series modules. In general, the following syntax is used to select a single channel:

```
@ <module address> ( <channel> ) )
```

Where:

- <module address> is the address of the 1260-145 module. This is a number in the range from 1 through 12, inclusive.
- <channel> is the 1260-145 relay to operate. This number can be obtained for a given card and a given relay by referring to **Figure 3-3** and one of the applicable card types illustrated in **Figures 3-5** through **3-11**. These figures provide a message-based channel descriptor (*MBC*) for each unique relay on any 1260-145 card.

Multiple individual channels may be specified using the following channel descriptor syntax:

```
@ <module address> ( <channel1> , <channel2>
, . . . , <channelN> ) [ ,data ]
```

A range of channels may be specified using the following channel descriptor syntax:

```
@ <module address> ( <first channel> :
<last channel> ) )
```

The following examples illustrate the use of the channel descriptors for the 1260-145:

|                 |                                      |
|-----------------|--------------------------------------|
| CLOSE (@8(0))   | Closes relay 0 at module address 8   |
| OPEN (@3(1000)) | Opens relay 1000 at module address 3 |

The message-based descriptors (*MBC*) provided in **Figures 3-5** through **3-11** serve a secondary purpose. In addition to

specifying an exact relay (i.e. relay 1000), the syntax of the message-based descriptor indicates which matrix the relay belongs to, and the column and row numbers which intersect the relay position. **Figure 3-4** identifies for each 1260-145 variant how to interpret the message-based descriptor to determine these parameters.

---

## Reply To The MOD:LIST? Command

The 1260-01T returns a reply to the MOD:LIST? Command. This reply is unique for each different 1260 series switch module. The syntax for the reply is:

<module address> : <module-specific identification string>

The <module-specific identification string> for the 1260-145 depends on the version. For the standard versions 1260-145A through 1260-145G these are:

1260-145A 9-4X4 MATRIX MODULE

1260-145B 3-4X12 MATRIX MODULE

1260-145C 2-4X16 MATRIX MODULE

1260-145D 4X36 MATRIX MODULE

1260-145E 2-8X8 MATRIX MODULE

1260-145F 8X16 MATRIX MODULE

1260-145G 12X12 MATRIX MODULE

So, for a 1260-145C whose <module address> is set to 8, the reply to this query would be:

8 : 1260-145C 2-4X16 MATRIX MODULE

## Operating The 1260-145 in Register-Based Mode

In register-based mode, the 1260-145 is operated by directly writing and reading to/from ports controlling eight relays each. To access the various registers the following details must be assembled to generate an absolute address that can be wrote or read from:

The control registers are located in the VXIbus A24 Address Space. The A24 address for a control register depends on:

1. The A24 Address Offset assigned to the 1260-01T module by the Resource Manager program. The Resource Manager program is provided by the VXIbus slot-0 controller vendor. The A24 Address Offset is placed into the "Offset Register" of the 1260-01T by the Resource Manager.
2. The <module address> of the 1260-145 module. This is a value in the range from 1 and 12 inclusive.
3. The 1260-145 control register to be written to or read from. Each register on the 1260-145 has a unique offset from the base address.

The base A24 address for the 1260-145 module may be calculated by:

$$(A24 \text{ Offset of the } 1260-01T) + (1024 \times \text{Module Address of } 1260-145).$$

The A24 address offset is usually expressed in hexadecimal. A typical value of  $204000_{16}$  is used in the examples that follow.

A 1260-145 with a module address of 7 would have the base A24 address computed as follows:

$$\begin{aligned} \text{Base A24 Address of } 1260-145 &= 204000_{16} + (400_{16} \times 7_{10}) \\ &= 205C00_{16} \end{aligned}$$

The control registers for Adapt-a-Switch plug-ins and conventional 1260-Series modules are always on odd-numbered A24 addresses. This number can be obtained for a given card and a given relay by referring to **Figure 3-3** and one of the applicable card types illustrated in **Figures 3-5** through **3-11**. These figures provide a register-based address offset and bit position (**Off-bit**) for each unique relay on any 1260-145 card. Once this offset is known, the absolute address where data is to be written or read from is simply assembled by adding the base address to the offset:

$$(\text{Base A24 } 1260-145 \text{ Address}) + \text{offset} = \text{absolute address}$$

If slot 7 is assumed to be occupied by a 1260-145A card for illustration purposes, from our example base A24 address computed earlier, the following absolute addresses would apply for the operations indicated:

|        |   |
|--------|---|
| 205C01 | Read or write to register controlling relays<br>0-3 and 100-103         |
| 205C0D | Read or write to register controlling relays<br>3000-3003 and 3100-3103 |

Writing to a control register location is a straightforward process. Setting a bit high in a control register causes the appropriate relay to close and setting the same bit low causes the relay to open. Because of the hardware architecture used in the 1260-145, a control register written to with a value will be *inverted* (one's complement) when read back.

It is especially important to realize that a single write operation to a control register will affect eight relays simultaneously. Therefore if only a single bit change is desired, the following process must be observed.

1. Read the register first, inverting the bit pattern if necessary
2. Mask the appropriate bit with an 'AND' operation and a byte mask with all undesired bits set to a '1' and the desired bit set to a '0' or '1' depending on whether the bit is to be set or cleared in the desired register
3. Write the masked data back into the register

As simple as this may seem, a number of products reported as faulty and sent back for repair are nothing more than the result of inappropriate register accesses.

The message-based descriptors (*MBC*) provided in **Figures 3-5** through **3-11** are not directly relative to register-based operation. They do, however, serve a secondary purpose in register-based operation. In addition to specifying an exact relay (i.e. relay 1000), the syntax of the message-based descriptor indicates which matrix the relay belongs to, and the column and row numbers which intersect the relay position. **Figure 3-4** identifies for each 1260-145 variant how to interpret the message-based descriptor to determine these parameters.

The VISA I/O library may be used to control the module. The VISA function viOut8() is used to write a single 8-bit byte to a control register, while viIn8() is used to read a single 8-bit byte from the control register. The following code example shows the use of viOut8() to update the 1260-145 module.

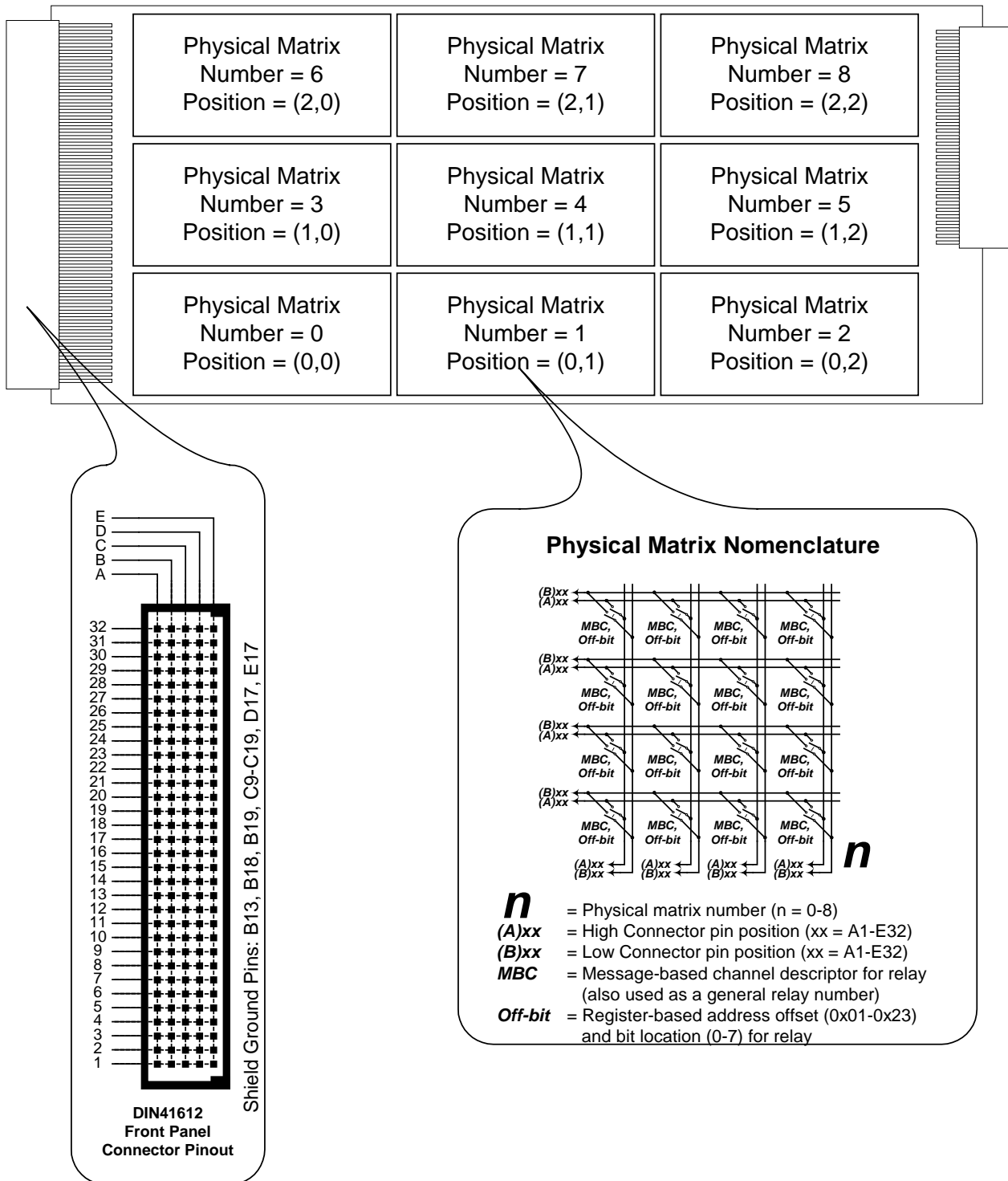

Figure 3-3, Numbering Nomenclature for all 1260-145 Variants



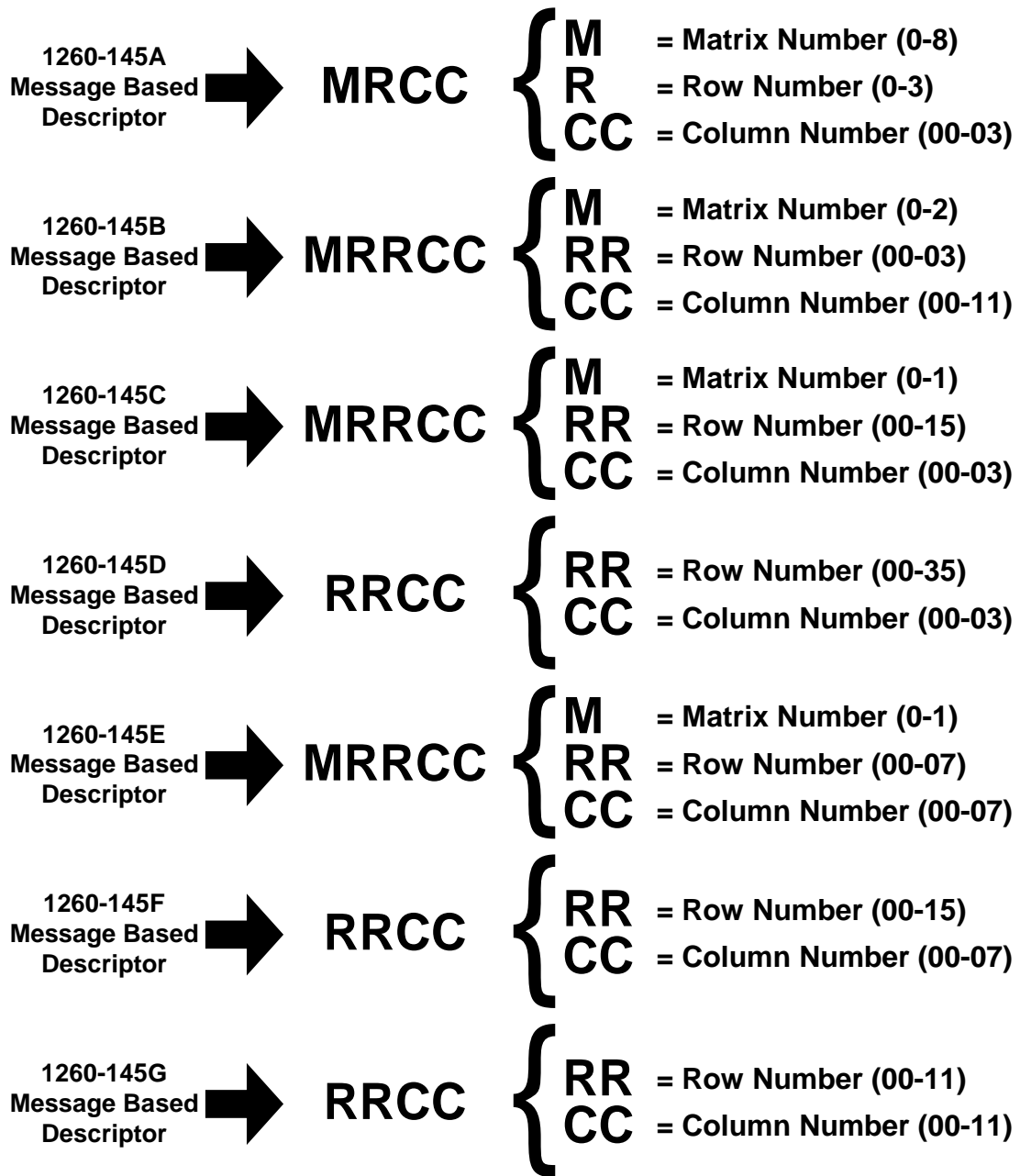

Figure 3-4, Message-Based Channel Descriptor to Physical Switch Orientation

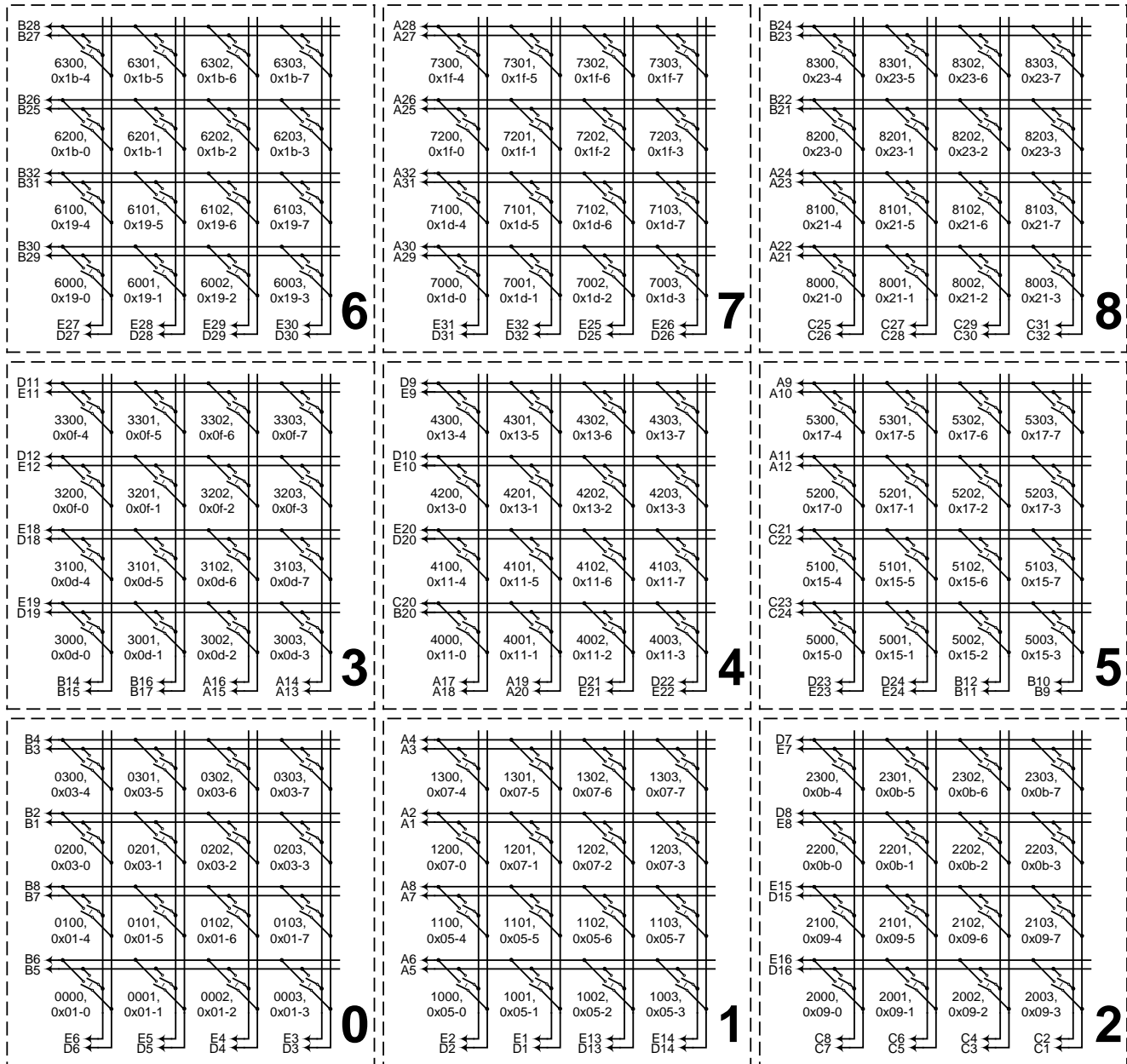

Figure 3-5, 1260-145A Connector/Channel Organization

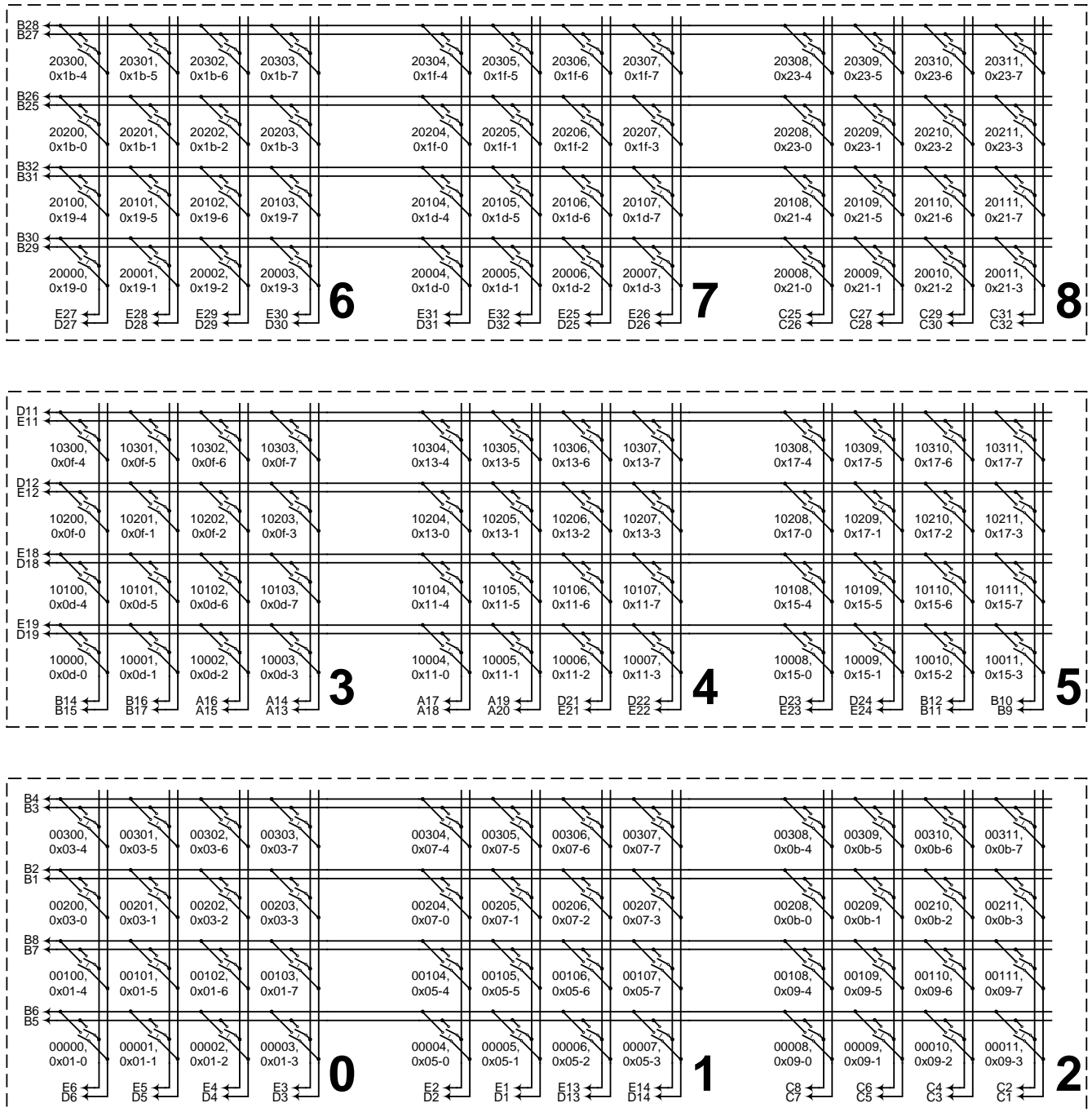

Figure 3-6, 1260-145B Connector/Channel Organization

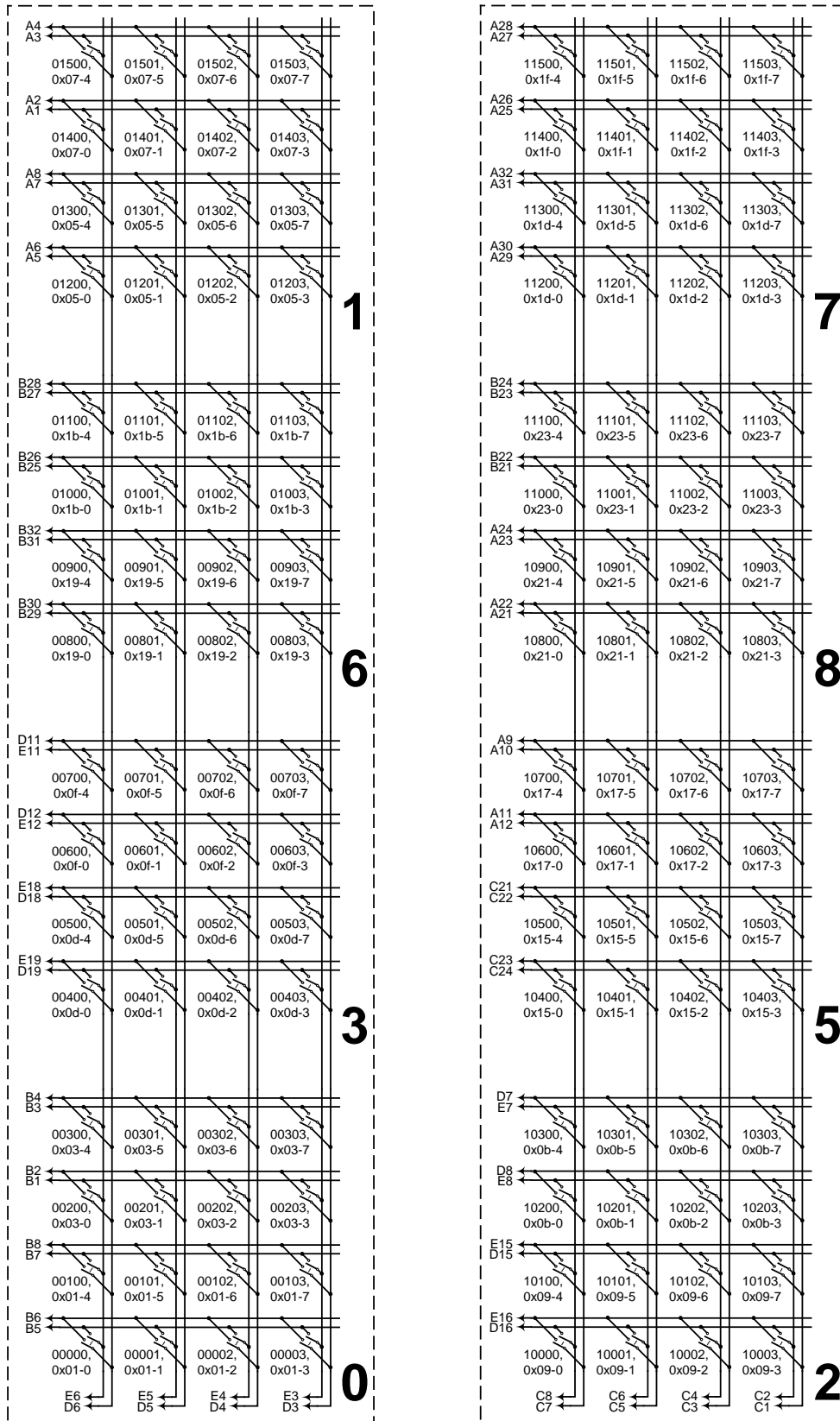

Figure 3-7, 1260-145C Connector/Channel Organization

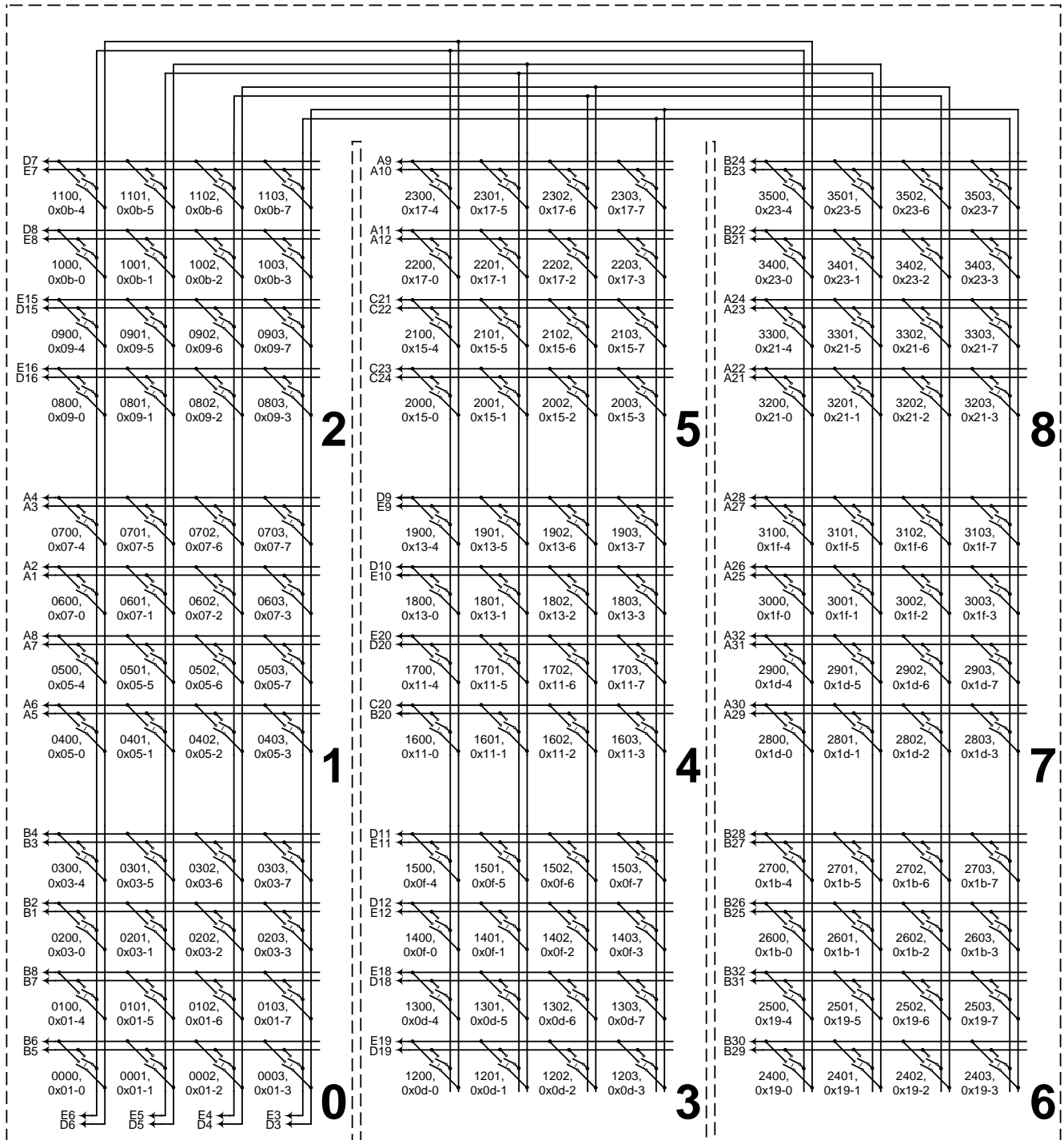

Figure 3-8, 1260-145D Connector/Channel Organization

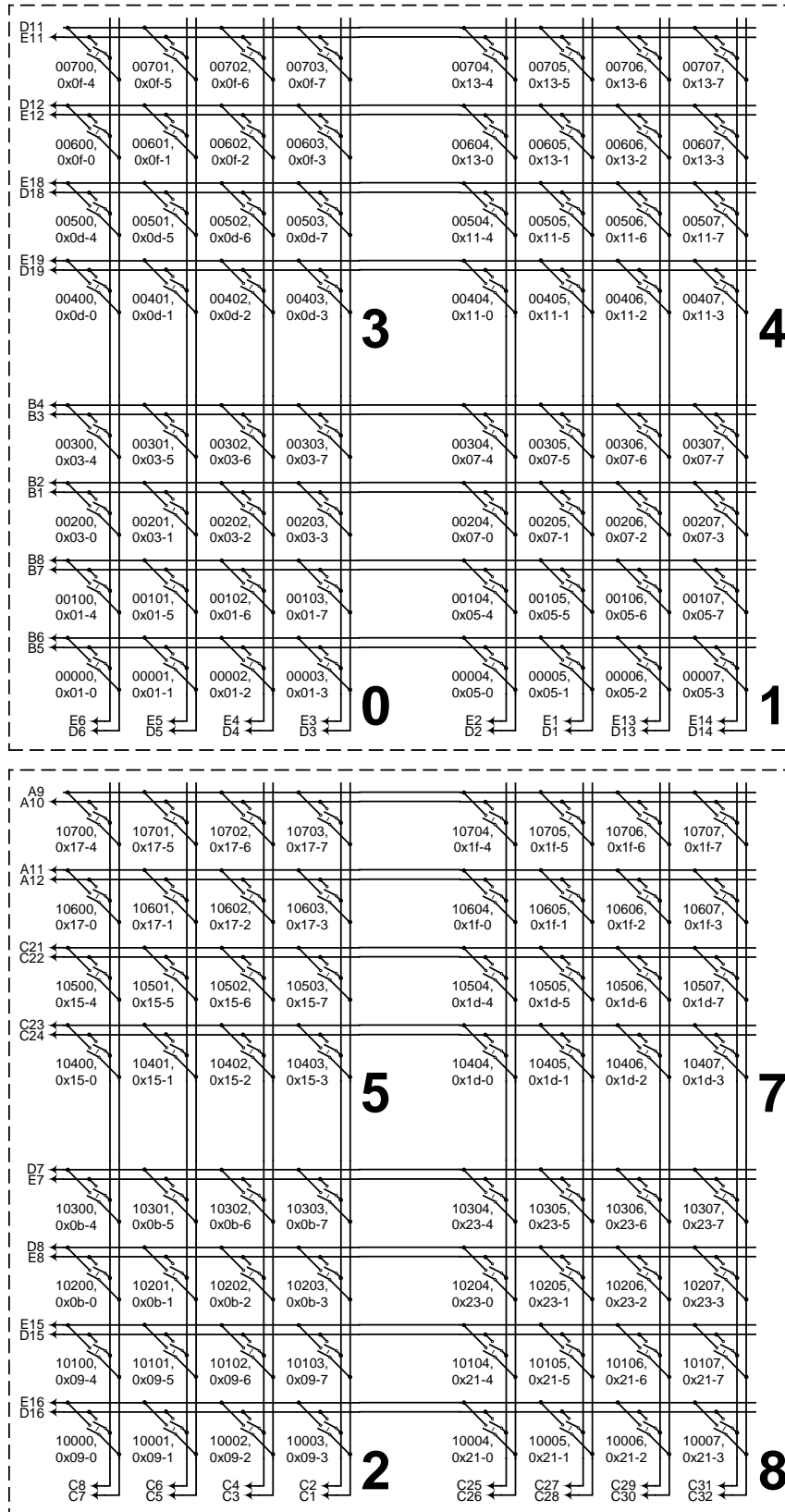

Figure 3-9, 1260-145E Connector/Channel Organization

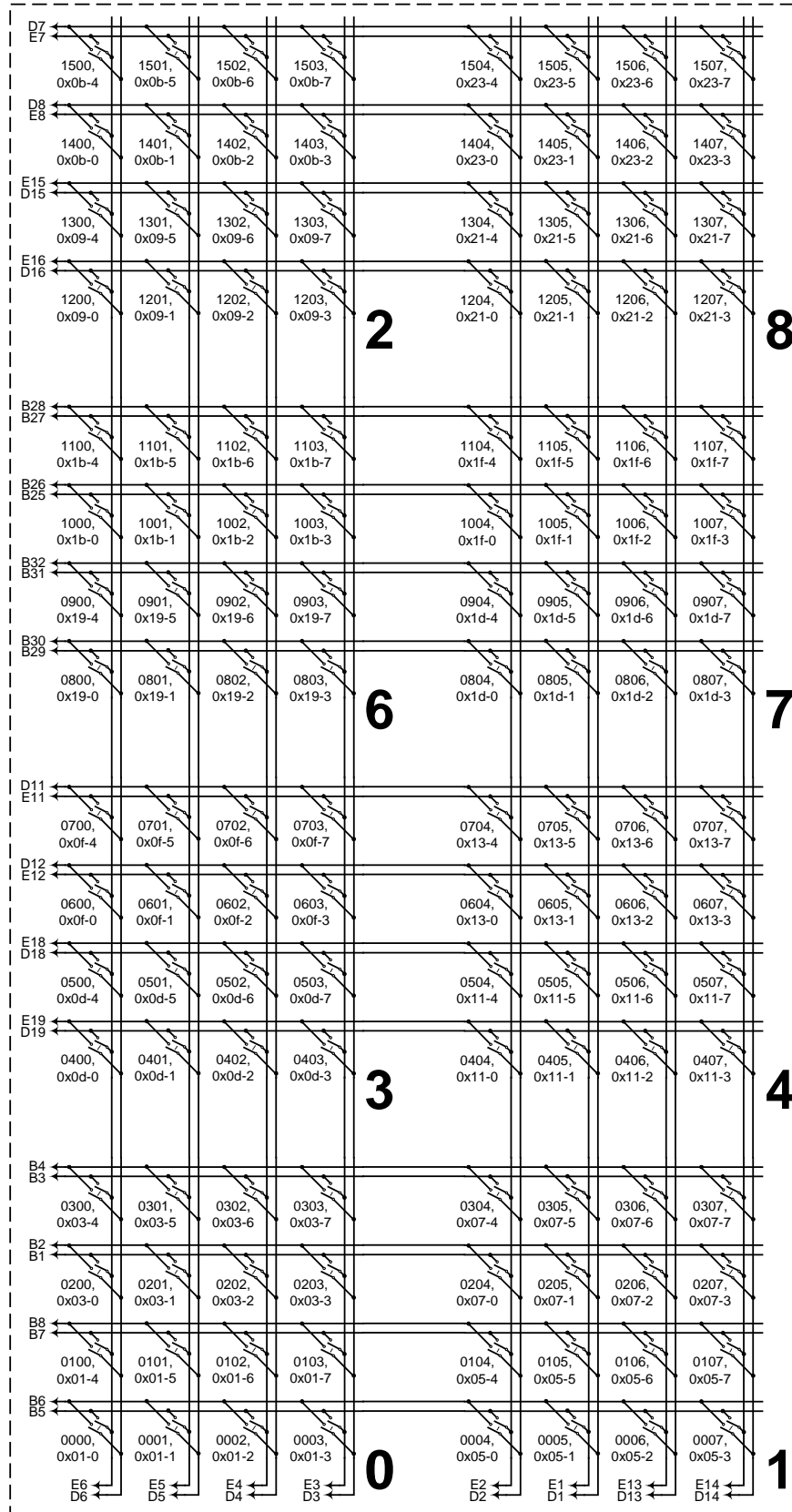

Figure 3-10, 1260-145F Connector/Channel Organization

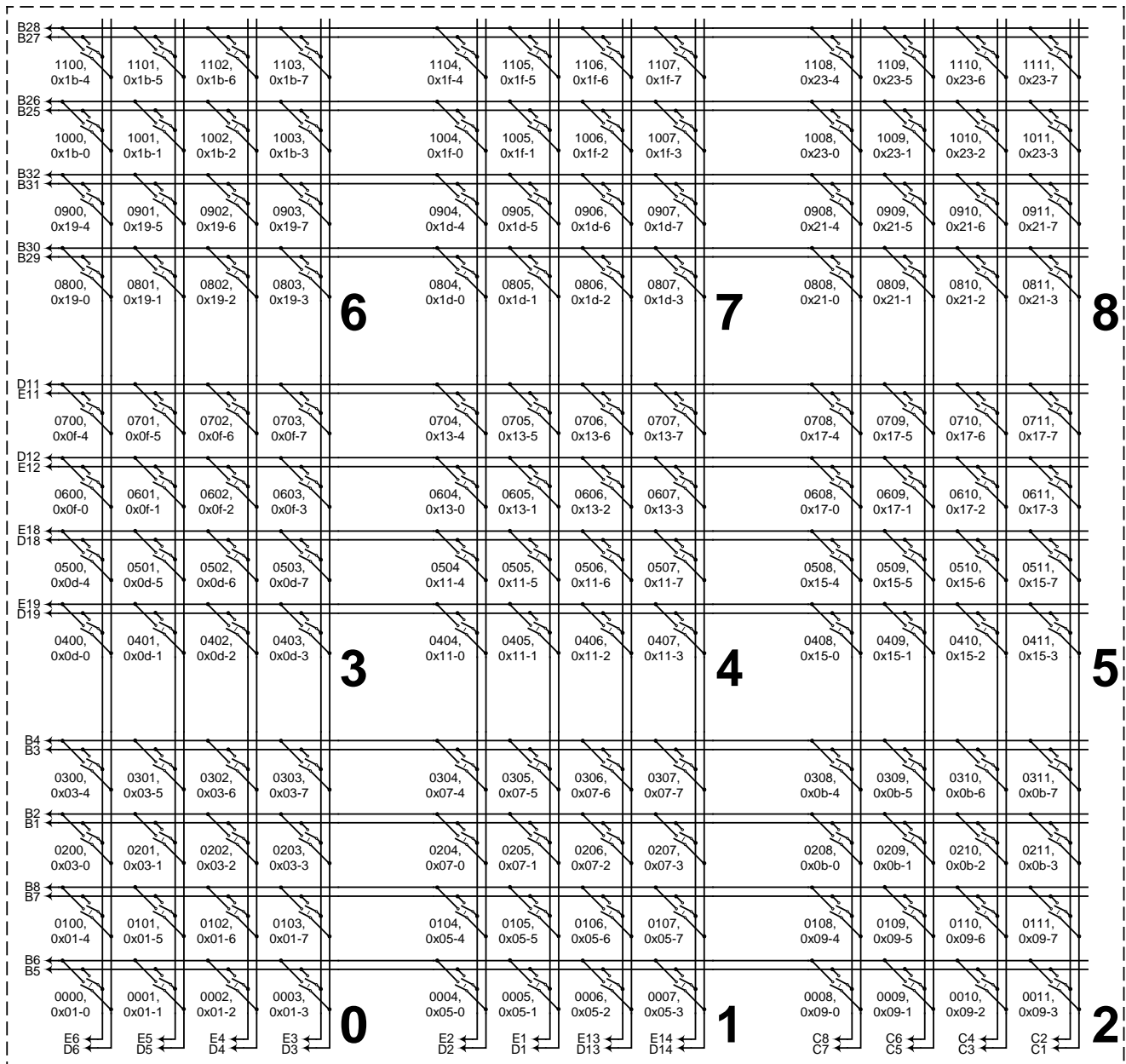

Figure 3-11, 1260-145G Connector/Channel Organization



## 1260-145 Example Code

```
#include <visa.h>

/* This example shows a 1260-01T at logical address 16 and a VXI/MXI */
/* interface */
#define RI1260_01_DESC      "VXI::16"

/* For a GPIB-VXI interface, and a logical address of 77 */
/* the descriptor would be: "GPIB-VXI::77" */

/* this example shows a 1260-145 with module address 7, control register
1, and write data of 0xAA */
#define MOD_ADDR_145      7
#define CONTROL_REGISTER  1
#define DATA_ITEM        0xAA

void example_operate_1260_145(void)
{
    ViUInt8 creg_val;
    ViBusAddress chan1_addr, offset;
    ViSession hdl1260;      /* VISA handle to the 1260-01T */
    ViSession hdlRM;       /* VISA handle to the resource manager */
    ViStatus error;        /* VISA error code */

    /* open the resource manager */
    /* this must be done once in application program */
    error = viOpenDefaultRM (&hdlRM);

    if (error < 0) {
        /* error handling code goes here */
    }

    /* get a handle for the 1260-01T */
    error = viOpen (hdlRM, RI1260_01_DESC, VI_NULL,VI_NULL, &hdl1260);
    if (error < 0) {
        /* error handling code goes here */
    }

    /* form the offset for control register 0 */
    /* note that the base A24 Address for the 1260-01T */
    /* is already accounted for by VISA calls viIn8() and */

```

```
/* viOut8() */

/* module address shifted 10 places = module address x 1024 */
chan1_addr = (MOD_ADDR_145 << 10) + 1;
offset = chan1_addr + (PORT_NUMBER << 1);

error = viOut8 (vi, VI_A24_SPACE, offset, DATA_ITEM);

if (error < 0)

    return( error );

/* close the VISA session */
error = viClose( hdl1260 );
if (error < 0) {
    /* error handling code goes here */
}
}
```

## Chapter 4

# OPTIONAL ASSEMBLIES

---

|            |                                       |     |
|------------|---------------------------------------|-----|
| 407664     | Connector Kit, 160 Pin Crimp.....     | 4-3 |
| 407408-001 | Cable Assy, 160 Pin, 6 ft, 24AWG..... | 4-4 |

This page was left intentionally blank.

Assembly 407664 Connector kit, 160 Pin, Crimp

Rev Date 7/30/98 Revision A

| # | Component  | Description          | U/M   | Qty Reqd. | REF |
|---|------------|----------------------|-------|-----------|-----|
| 1 | 602258-116 | CON-CAB-RCP160C,100S | -E EA | 1.000     |     |
| 2 | 602258-900 | TRMCRP-SNP-U-F26-20G | -E EA | 170.000   |     |

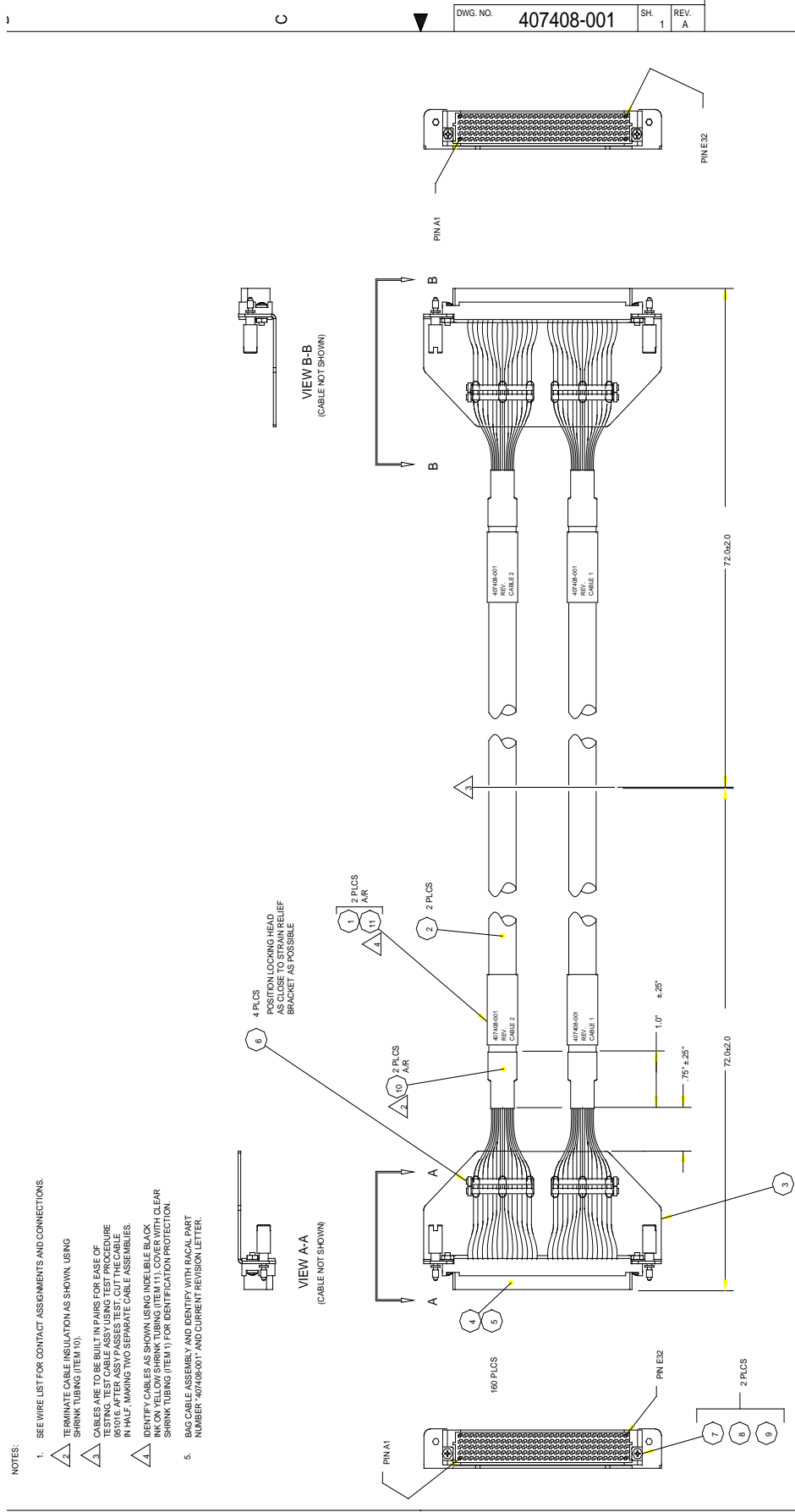

- NOTES:
1. SEE WIRE LIST FOR CONTACT ASSIGNMENTS AND CONNECTIONS.
  2. TERMINATE CABLE INSULATION AS SHOWN, USING SHRINK TUBING (ITEM 10).
  3. CABLES ARE TO BE BUILT IN PAIRS FOR EASE OF TESTING. TEST CABLE ASSY USING TEST PROCEDURE 851016. AFTER ASSY PASSES TEST, CUT THE CABLE IN HALF, MAKING TWO SEPARATE CABLE ASSEMBLIES.
  4. IDENTIFY CABLES AS SHOWN USING INDELIBLE BLACK INK ON YELLOW SHRINK TUBING (ITEM 11). COVER WITH CLEAR SHRINK TUBING (ITEM 1) FOR IDENTIFICATION PROTECTION.
  5. BAG CABLE ASSEMBLY AND IDENTIFY WITH FACAL PART NUMBER: "407408-001" AND CURRENT REVISION LETTER.